



## Article

# Solar Cooling for Mediterranean Region as a Crop Storage Technology

Buyadgie, O.D, Buyadgie, D.I, Drakhnia, O.Y, Artemenko, S.V, Chamchine, Andrei and Vityuk, Y.M

Available at <http://clock.uclan.ac.uk/19462/>

*Buyadgie, O.D, Buyadgie, D.I, Drakhnia, O.Y, Artemenko, S.V, Chamchine, Andrei ORCID: 0000-0001-8653-8669 and Vityuk, Y.M (2016) Solar Cooling for Mediterranean Region as a Crop Storage Technology. Energy Procedia, 91 . pp. 728-735. ISSN 1876-6102*

It is advisable to refer to the publisher's version if you intend to cite from the work.  
<http://dx.doi.org/10.1016/j.egypro.2016.06.236>

For more information about UCLan's research in this area go to <http://www.uclan.ac.uk/researchgroups/> and search for <name of research Group>.

For information about Research generally at UCLan please go to <http://www.uclan.ac.uk/research/>

All outputs in CLoK are protected by Intellectual Property Rights law, including Copyright law. Copyright, IPR and Moral Rights for the works on this site are retained by the individual authors and/or other copyright owners. Terms and conditions for use of this material are defined in the [policies](#) page.

SHC 2015, International Conference on Solar Heating and Cooling for Buildings and Industry

## Solar cooling for Mediterranean region as a crop storage technology

Olexiy D. Buyadgie<sup>a,b,\*</sup>, Dmytro I. Buyadgie<sup>b</sup>, Oleksii Y. Drakhnia<sup>b</sup>, Sergiy V. Artemenko<sup>a,c</sup>, Andrei V. Chamchine<sup>d</sup>, Yuriy M. Vityuk<sup>e</sup>

<sup>a</sup>V.S. Martynovsky Institute of Refrigeration, Cryogenic Technologies and Eco-Energetics, 1/3, Dvoryans'ka str., 65026, Odessa, Ukraine

<sup>b</sup>Wilson, 15/13, Mikhailivs'ka str., 65005, Odessa, Ukraine

<sup>c</sup>Sustainable Refrigeration Technology Center, 1/3, Dvoryans'ka str., 65026, Odessa, Ukraine

<sup>d</sup>University of Central Lancashire, Preston PR1 2HE, UK

<sup>e</sup>Servus, 47/3, Marshala Zhukova str., #20, 65114, Odessa, Ukraine

---

### Abstract

The Mediterranean region is a major supplier of fruits and vegetables to Europe. Fruit harvesting continues the year round, including certain fruits to be harvested from September to June. The follow up of the specific temperature and humidity storage conditions becomes significantly energy intensive that adversely affects the energy balance of exporters, especially when the producing country is run out of affordable energy sources. In order to reduce the energy costs during the crop storage and avoid the crop wastage, the solar ejector cooling systems were introduced. These systems developed recently, are fully autonomous, does not contain mechanically moving parts, reliable and durable in performance. In addition, the new type of thermopump with high energy and performance characteristics was elaborated and tested within the ejector cooling system, driven by the imitated low-grade heat. The results of theoretical and experimental study of the thermopump and the ejector refrigeration system were described in the study along with factors that affect the system's efficiency.

The crop storages operating regimes were reviewed during the storage season for the selected products. Temperature ranges defined for systems with constant area ratio ejector at COP values remains stable. Cold accumulators or duplicate conventional systems, applied during the night were considered as backup systems, supporting a non-stop operation.

© 2016 Published by Elsevier Ltd. This is an open access article under the CC BY-NC-ND license (<http://creativecommons.org/licenses/by-nc-nd/4.0/>).

Peer-review by the scientific conference committee of SHC 2015 under responsibility of PSE AG

*Keywords:* solar thermal, ejector, cooling, crop storage, thermopump

---

---

\* Corresponding author. Tel.: +380-48-734-8010; fax: +380-48-734-9010.  
E-mail address: [buyadgie@wilson-ukraine.com](mailto:buyadgie@wilson-ukraine.com)

## 1. Introduction

The commercial scale fruit and vegetables production is often carried out in regions of a high solar radiation activity and Mediterranean Sea coast is among them.

### Nomenclature

|       |                                      |
|-------|--------------------------------------|
| $G$   | mass flow rate (kg/s)                |
| $p$   | pressure (kPa)                       |
| $f$   | section area (m <sup>2</sup> )       |
| $\Pi$ | relative pressure                    |
| $a$   | sound speed (m/s)                    |
| $k$   | adiabatic index                      |
| $v$   | specific volume (m <sup>3</sup> /kg) |
| $Q$   | heat load (kW)                       |
| $T$   | temperature (K)                      |
| $t$   | temperature (°C)                     |

### Subscripts

|        |                                    |
|--------|------------------------------------|
| $wf$   | working fluid                      |
| $crit$ | critical parameter                 |
| $Cp$   | specific heat capacity (kJ/(kg K)) |
| $gen$  | generation parameter               |
| $cond$ | condensation parameter             |
| $eva$  | evaporation parameter              |

At the same time, the crop storage process is always energy intensive that increases the production costs and affects the competitiveness. The power supply in Mediterranean region is no uniform by countries and is always in a shortage due to the fossil nature of the most popular energy sources. Bearing in mind the high production scale and significant cooling capacity required for the crop storage provided by the electrical cooling devices, it is a perfect scope for renewable energy sources utilization, such as solar thermal, to preserve the electrical power for other economical needs.

The last decade strategy was focused on centralization policy for crop plantations. It led to small farms smashup due to electricity consumption for storage purposes that is a critical pricing factor. In order to survive, small producers have to search for an opportunity to use alternative and cheap energy systems to operate crop storage facilities for their competitive positioning and growth on the market. The latest researches present the Solar Ejector Refrigeration System (SERS) for such small crop producers. Having a number of important advantages such as simplicity in design and operation, high reliability and durability, it can accommodate almost entire crop storage requirement during the peak loads and save thousands of kilowatts of electrical power to match, preventing from CO<sub>2</sub> and other green house gasses emission. Interestingly, that the higher solar intensity corresponds to the higher cooling capacity demand making solar cooling technologies viable for application and energy efficient.

## 2. Theoretical and experimental study of the autonomous Ejector Refrigerating System (ERS)

One of the main challenges of the ERS wide expansion is a problem to feed a high-pressure vapor generator with the nearly saturated liquid. The latest achievements resolve this problem in a very reliable way [1-7]. In a result, the ERS with thermopump was built, which operates by using a part of the vapor from vapor generator (Fig. 1) [6,7].

The composition of the experimental test bench includes:

- - Shell-and-tube vapor generator, heated by the hot water produced by the simulated electrical boiler.
- - Ejector with axially moving nozzle and replaceable diffusers;
- - Shell-and-tube water-refrigerant condenser;
- - Plate-type evaporator;
- - Gravitational type thermopump with return valves and solenoid valves system;
- - Measuring vessel and flow meters;
- - Throttling and check valves;
- - Standard pressure gages;
- - Thermoelectric thermocouples with potentiometer;
- - Automatic control panel;
- - 2 water pumps.

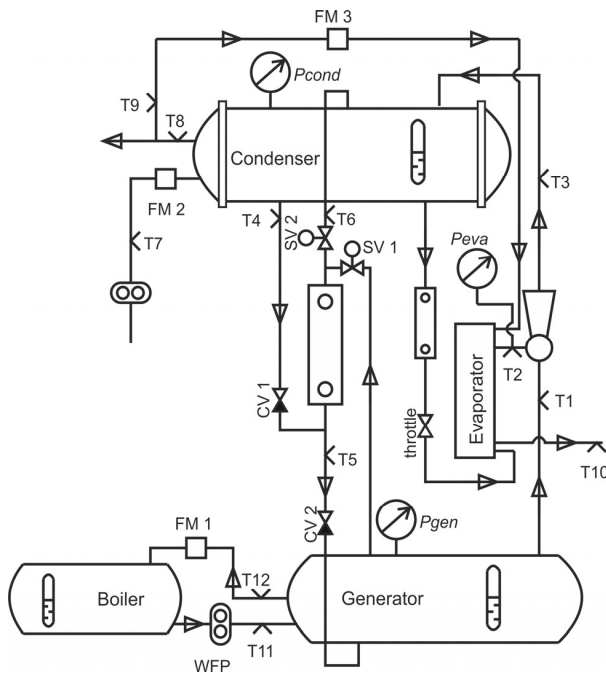

Fig. 1. ERS experimental unit.  $P_{gen}$ ,  $P_{cond}$ ,  $P_{eva}$  – generation, condensation, evaporation pressures; FM1,FM2,FM3 – water flow meters; SV1,SV2 – solenoid valves; CV1,CV2 – check valves; T1-T12 – thermocouple.

The ERS components are placed as follows: the water-cooled condenser is located on the upper level, while the vapor generator is located on the lower level. The central part occupied by the thermopump of the calibrated design, since it also serves as a measuring vessel to determine the working fluid flow. The thermopump is connected to the vapor generator and the condenser by the vapor and liquid lines. The ejector is positioned nearby the thermopump and the evaporator, so its suction line is positioned as close as possible to the evaporator, while the diffuser part is faced in a direction of the condenser. Another measuring receiver is placed on the liquid line between the condenser and the expansion valve to identify the flow rate of the refrigerant through the evaporator.

The first series of experiments were carried out to determine the actual COP of the thermopump without the evaporator load. Before the measurement started, the steady state was achieved and all cycle parameters were set according to the design conditions: generation temperature  $T_{gen} = 358\text{K}$ ; condensation temperature  $T_{cond} = 308\text{K}$ ;

evaporation temperature  $T_{eva}=285\text{K}$ . In this case the flow that passed through the nozzle is determined by the nozzle critical diameter and the ejector's input and output parameters (Eq. 1-3).

$$G_{wf} = \frac{k_{wf} \Pi_{wf,crit} \rho_{wf} f_{wf,crit}}{a_{wf,crit}} \quad (1)$$

$$\Pi_{wf,crit} = \left( \frac{2}{k+1} \right)^{\frac{k}{k-1}} \quad (2)$$

$$a_{wf,crit} = \sqrt{2 \frac{k}{k+1}} \sqrt{\rho_{wf} u_{wf}} \quad (3)$$

The working fluid flow was identified by the system's thermal and material balance. The flow rate through the condenser was determined similarly. The fluid delivery to the steam generator was determined directly by measuring the flow time required to empty the thermopump active chamber. Then the mass losses of the steam in thermopump were defined as a difference between the flow rate of the fluid from the pump and the steam flow through the nozzle. Heat losses through the insulation of the steam generator are the difference of heat coming from the boiler and the heat consumed by the overall refrigerant's flow. (Eq. 4-5).

$$G_{water} C_{p,water} \Delta t = (G_{wf,ejector} + G_{wf,pump}) (h_{gen} - h_{cond}) \quad (4)$$

$$(G_{wf,ejector} + G_{wf,pump}) = \frac{G_{water} C_{p,water} \Delta t}{(h_{gen} - h_{cond})} \quad (5)$$

All the defined values were averaged down to reduce the measurement error and presented in Table 1.

Table 1. The experimental results.

| Cycle time, s | Mass flow rate, kg/s |          |            | Power consumption, kW |        |            |           |
|---------------|----------------------|----------|------------|-----------------------|--------|------------|-----------|
|               | Ejector              | Pump     | Evaporator | Ejector               | Pump   | Evaporator | Condenser |
| 16            | 0.0178               | 0.003723 | 0.008544   | 3.83                  | 0.7916 | 1.598      | 6.1596    |
| 30            | 0.0176               | 0.001986 | 0.008095   | 3.806                 | 0.422  | 1.554      | 5.742     |
| 40            | 0.0173               | 0.001489 | 0.008304   | 3.678                 | 0.316  | 1.539      | 5.513     |
| 42            | 0.0179               | 0.001418 | 0.008448   | 3.844                 | 0.301  | 1.581      | 5.676     |

Tests were carried out for 5 days, each set of measurements was carried out for 5-10 minutes in order to determine the flow rate of the pump as accurately as possible. The cycle time included the time of charging and discharging of the thermopump chamber, response time of the control units and the passage of a shock wave through the pipeline to the check valve. Therefore, each cycle had different durations. Similarly, the consumption of heating and cooling water was also determined, when measured over a longer period. The measurements were carried out both by the flow meters and using the volumetric method to compare results and check the accuracy class of the water flow meters. The data on the refrigerant temperature and water were gathered and stored on a computer, switching the testing conditions when required. One of the operating conditions variant is shown on the diagram below (Fig. 2).

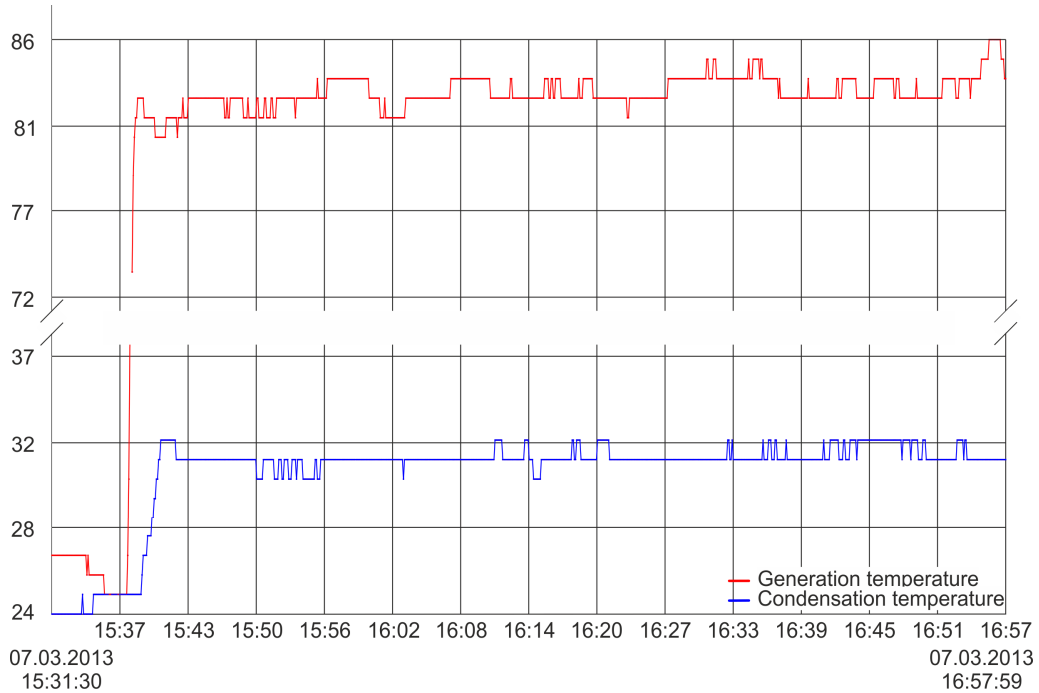

Fig. 2. Experiment temperature diagram, shows the steady-state reaching.

The flow rate of the motive and refrigerant flows and cycle nodal points parameters were measured to determine the characteristics of the experimental prototype. An aggregated entrainment ratio for the designed cycle parameters was measured. Its value was 0.48, which is 4.1% below the value of 0.5 obtained by the CFD-model. The calculated value of entrainment ratio was 0.469, which is 2.34% lower than experimental and 6.6% lower than the CFD model results (Fig. 3). It proves that the velocity coefficients, applied in the theoretical calculations, reduced the estimated value of the entrainment ratio due to the lower viscosity of the refrigerants compared to water steam, proposed in the 1-D model. Clarification of these coefficients can approach the calculated values to the CFD model and experiment values.

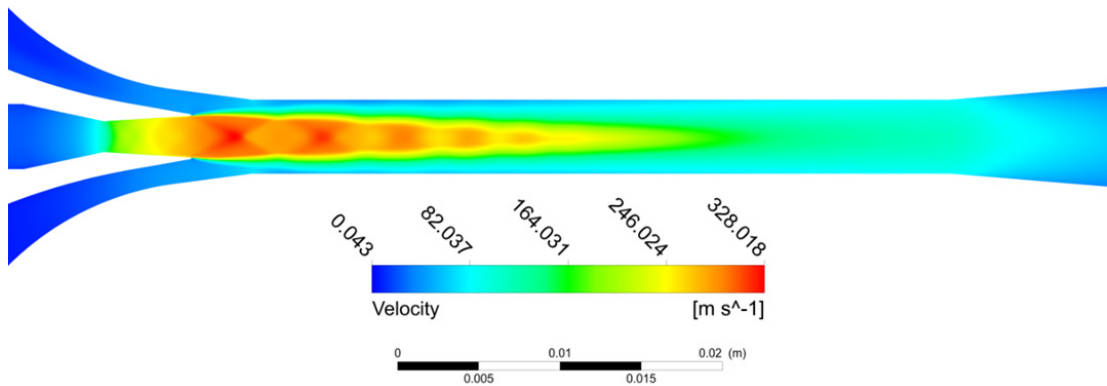

Fig. 3. CFD model of the ejector.

An integral COP of the system is determined as (Eq. 6):

$$COP = \frac{Q_{eva}}{Q_{ejector} + Q_{pump}} \quad (6)$$

In our case, the heat for the thermopump operation, reduces the COP by 10-12% net. (Fig. 4).

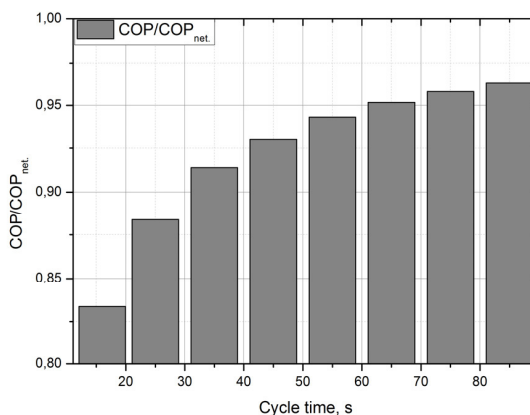

Fig. 4. Dependence of the ERS COP to COP net. from thermopump cycle time.

Compared to the mechanical pumps that use electricity at a rate of 5-10% [8] of the generator heat, the thermopump is more cost efficient, reliable in the operation and does not require liquid subcooling. Considering that the heat exergetical COP equals to 0.1275 for the designed operating parameters, the equivalent low-grade heat flow for the mechanical pump is about 39-78%.

### 3. Additional energy supply for solar ERS

Almost all Mediterranean countries lies in the area of sustainable and high solar insolation level, which can be used as a main energy source for cold production. Even the cheapest solar collectors can achieve the desired temperatures. For example, in Egypt the solar radiation level reaches 8 kW/m<sup>2</sup> and average value in region equals 5-6 kW/m<sup>2</sup>. It is enough to produce 1 kW of cooling capacity using ERS with 2-3 m<sup>2</sup> of the solar collector area.

The main disadvantage of solar systems is unstable heat supply during daytime and its absence during the night. In addition, solar intensity depends on the season. In off-season cooling demand is low but it still needs high generation temperatures. In addition, ERS can operate as a heat pump in a short time periods, when the ambient temperatures is below 0°C.

The nominal cooling capacity should be increased in 2-2.5 times to provide continuous cold supply. But its rise the cost of the system. Additional heat or cold accumulators have an adverse effect on the capital expenditures. The conventional vapor compression refrigeration systems could be applied as a backup system to ensure the continuing cooling production in a period of solar absence. It is a viable solution, considering low electricity tariffs during the nighttime. Sometimes solar collector can be integrated with a heat pump [9] or backup heater. Alternative heat supply can be achieved using heat generators from the available fuels. The decision in a favor of the most appropriate means of the effective cooling capacity production could be made after a comparative analysis of the particular thermophysical and economical situations.

### 4. Operating parameters in Mediterranean area

The storage regime of various fruits lies at temperature range 1-3°C and requires evaporation temperature to be maintained at a level of -2 - -4°C [10]. An ambient temperature fluctuates within a range of 5-35°C except the days when maximum and minimum temperatures occur. It allows varying of condensation temperatures in a wide range.

The solar insolation level correlates with ambient temperatures. It is possible to adjust the generation temperature with condensation temperature, keeping the solar collector and condenser areas constant that essentially simplifies the ERS unit operation. The calculations showed that using of one ejector with constant critical nozzle and area ratio at various regimes is possible. For example, ERS on DME working fluid can operate at condensation temperature  $t_{cond}=14-25^{\circ}\text{C}$  and generation temperature  $t_{gen}=80-95^{\circ}\text{C}$  using one ejector with area ratio  $f_{mix}/f_{crit}=10.42$  and critical nozzle diameter  $R_{crit}=1.157\text{mm}$ . At the same time, the evaporation temperature and the cooling capacity produced are constant. The further increase of the condensation temperature up to  $28-35^{\circ}\text{C}$  requires ejector replacement, but it slightly differs in dimensions. For ERS with  $\text{CF}_3\text{I}$  working fluid, the condensation temperature varies at a level of  $t_{cond}=14-23\text{C}$  and generation temperature  $t_{gen}=80-95^{\circ}\text{C}$ , ejector area ratio equals to  $f_{mix}/f_{crit}=10.308$  and critical nozzle diameter  $R_{crit}=1.886\text{ mm}$ . With another ejector, the system can operate at generation temperature  $t_{gen}=95-110^{\circ}\text{C}$  and condensation temperature  $t_{cond}=23-35^{\circ}\text{C}$  (Table 2).

Table 2. Calculation results of ERS and ejector at various generation and condensation temperatures.

| Working fluid         | $t_{gen}$ | $t_{cond}$ | $t_{eva}$ | $Q_{eva}$ | $U$   | $COP$ | $f_{mix}/f_{crit}$ | $R_{crit}$ |
|-----------------------|-----------|------------|-----------|-----------|-------|-------|--------------------|------------|
| DME                   | 80        | 14         |           | 10,021    | 0,808 | 0,691 | 10,420             | 1,157      |
|                       | 85        | 16,5       |           | 9,993     | 0,723 | 0,614 | 10,415             | 1,157      |
|                       | 90        | 19,1       |           | 9,963     | 0,645 | 0,545 | 10,427             | 1,157      |
|                       | 95        | 22,4       | -2        | 9,604     | 0,557 | 0,468 | 10,419             | 1,157      |
|                       | 100       | 26         |           | 10,175    | 0,477 | 0,400 | 10,430             | 1,215      |
|                       | 105       | 30,076     |           | 10,062    | 0,404 | 0,339 | 10,429             | 1,235      |
|                       | 110       | 34,82      |           | 9,564     | 0,337 | 0,283 | 10,430             | 1,235      |
| R124                  | 80        | 14         |           | 10,112    | 0,839 | 0,650 | 11,970             | 1,753      |
|                       | 85        | 16,9       |           | 9,670     | 0,720 | 0,550 | 11,940             | 1,753      |
|                       | 90        | 19         |           | 10,386    | 0,655 | 0,495 | 12,514             | 1,795      |
|                       | 95        | 22,24      | -2        | 9,899     | 0,558 | 0,416 | 12,510             | 1,795      |
|                       | 100       | 25,83      |           | 9,401     | 0,471 | 0,347 | 12,514             | 1,795      |
|                       | 105       | 29,88      |           | 10,280    | 0,394 | 0,287 | 12,573             | 1,927      |
|                       | 110       | 35         |           | 9,586     | 0,319 | 0,231 | 12,570             | 1,927      |
| $\text{CF}_3\text{I}$ | 80        | 14         |           | 10,480    | 0,828 | 0,706 | 10,312             | 1,886      |
|                       | 85        | 16,6       |           | 10,470    | 0,740 | 0,628 | 10,304             | 1,886      |
|                       | 90        | 19,4       |           | 10,437    | 0,659 | 0,557 | 10,310             | 1,886      |
|                       | 95        | 22,77      | -2        | 10,149    | 0,572 | 0,482 | 10,311             | 1,886      |
|                       | 100       | 26         |           | 10,302    | 0,506 | 0,427 | 10,612             | 1,900      |
|                       | 105       | 30,462     |           | 9,852     | 0,425 | 0,360 | 10,612             | 1,900      |
|                       | 110       | 35         |           | 10,007    | 0,363 | 0,310 | 10,915             | 1,925      |
| Isobutane             | 80        | 14         |           | 10,424    | 0,860 | 0,646 | 10,420             | 1,624      |
|                       | 85        | 16,7       |           | 10,032    | 0,751 | 0,554 | 10,429             | 1,624      |
|                       | 90        | 19,54      |           | 9,930     | 0,677 | 0,490 | 10,694             | 1,624      |
|                       | 95        | 21         | -2        | 10,358    | 0,623 | 0,445 | 11,160             | 1,639      |
|                       | 100       | 24,02      |           | 9,893     | 0,541 | 0,379 | 11,167             | 1,639      |
|                       | 105       | 27,29      |           | 10,295    | 0,466 | 0,321 | 11,161             | 1,715      |
|                       | 110       | 31         |           | 9,890     | 0,395 | 0,268 | 11,104             | 1,736      |



|       |     |       |    |        |       |       |        |       |
|-------|-----|-------|----|--------|-------|-------|--------|-------|
|       | 80  | 14    |    | 10,339 | 0,852 | 0,684 | 11,464 | 1,763 |
|       | 85  | 16,71 |    | 9,964  | 0,741 | 0,587 | 11,464 | 1,763 |
|       | 90  | 19    |    | 10,250 | 0,666 | 0,522 | 11,766 | 1,790 |
| R142b | 95  | 21,9  | -2 | 9,835  | 0,578 | 0,447 | 11,765 | 1,790 |
|       | 100 | 25    |    | 10,100 | 0,498 | 0,381 | 11,738 | 2,200 |
|       | 105 | 28,45 |    | 10,350 | 0,423 | 0,320 | 11,638 | 1,938 |
|       | 110 | 32    |    | 9,850  | 0,361 | 0,270 | 11,633 | 1,938 |

## 5. Conclusions

1. The climate conditions of the Mediterranean region allow securing the entire Europe with fruits and vegetables a year round. In addition, the solar energy can be utilized twice, for cultivation purposes and for crops cooling and storage.
2. It is preferred to use ERS as a most affordable, simple and reliable system among all existed low-grade heat driven cooling systems.
3. R124, DME, CF<sub>3</sub>I, R600a are among the effective working fluids to be applied in the ERS for the designed working parameters. All the refrigerants correspond to the ODP and GWP regulations in the Montreal and Kyoto protocols.
4. It is recommended to use 2-3 ejectors to match the variable ambient conditions. Every ejector works within a specified range of temperatures without changing their energy performance characteristics.
5. Crop storage facilities can be built using the cost-effective materials with easy assembling and relocation.

## References

- [1] Keller S.Yu. Injectors. Mashinostroenie pub. House, 1954.
- [2] Krasnyuk L.S. Low-capacity freon ejector refrigeration systems. Dissertation, 1971.
- [3] Lehmus AA. Research and design of the marine pumpless ejector refrigeration system. Dissertation, 1973.
- [4] Srisastra P., Aphornratana S. A circulating system for a steam jet refrigeration system. Applied Thermal Engineering, 2005; 25: pp. 2247-2257.
- [5] Buyadgie D., Buyadgie O., Drakhnia O., Artemenko S., Chamchine A. Solar cooling technologies using ejector refrigeration system. Energy Procedia 2013; 30: 912-920.
- [6] Buyadgie D.I., Buyadgie O.D., Drakhnia O.Y., Sladkovskiy Ye. M., Chamchine A.V. Prototype of ejector refrigeration system with thermopump testing in air-conditioning mode. The 5th International Conference on Cryogenics and Refrigeration ICCR2013, Hangzhou, China, 2013.
- [7] Buyadgie D., Buyadgie O. Method for liquid supply from low pressure cavity to high pressure cavity and installation for its realization (variants). Patent UA №102488, pub date: 10.07.2013.
- [8] Koshkin N., Sakun I., Bambushek E., Buharin N., Gerasimov E., Ilin A., Pekarev V., Stukalenko A. and Timofeev L. Refrigerating machines. Leningrad: Mashinostroenie pub. House; 1985.
- [9] Buyadgie D., Buyadgie O. 2012, Method for combined cold and heat supply by utilizing solar energy and installation for its realization. Patent UA №98716, pub. date: 11.06.2011.
- [10] Ivanova, T.N., Zhitnikova, V.S., Levgerova, N.S., 2009. Technology of fruit, berries and vegetables storage. Orel State Technical University, Russia.