

Central Lancashire Online Knowledge (CLoK)

Title	Analysis Photovoltaic System in Relation to Tracking and Non-Tracking System
Type	Article
URL	https://clock.uclan.ac.uk/36933/
DOI	https://doi.org/10.4172/2090-4541.1000284
Date	2021
Citation	Khilji, Muhammad Danial and Munir, Saad Bin (2021) Analysis Photovoltaic System in Relation to Tracking and Non-Tracking System. Journal of Fundamentals of Renewable Energy and Applications, 11 (2). pp. 1-9. ISSN 2090-4541
Creators	Khilji, Muhammad Danial and Munir, Saad Bin

It is advisable to refer to the publisher's version if you intend to cite from the work.
<https://doi.org/10.4172/2090-4541.1000284>

For information about Research at UCLan please go to <http://www.uclan.ac.uk/research/>

All outputs in CLoK are protected by Intellectual Property Rights law, including Copyright law. Copyright, IPR and Moral Rights for the works on this site are retained by the individual authors and/or other copyright owners. Terms and conditions for use of this material are defined in the <http://clock.uclan.ac.uk/policies/>

See discussions, stats, and author profiles for this publication at: <https://www.researchgate.net/publication/349319190>

Analysis Photovoltaic System in Relation to Tracking and Non-Tracking System

Article in *Journal of Fundamentals of Renewable Energy and Applications* · February 2021

DOI: 10.4172/2090-4541.1000284

CITATIONS

0

READS

9

2 authors:



Danial Khilji

University of Central Lancashire

1 PUBLICATION 0 CITATIONS

SEE PROFILE



Saad Bin Munir

University of Central Lancashire

1 PUBLICATION 0 CITATIONS

SEE PROFILE

Analysis Photovoltaic System in Relation to Tracking and Non-Tracking System

Muhammad Danial Khilji^{1*}, Saad Bin Munir¹

¹ Department of Data Sciences, University of Central Lancashire, United Kingdom

ABSTRACT

The increasing demand of electricity has been a great concern in recent years. The increasing demand and environmental (global warming) issues urged scientists to evolve in the field of renewable energy. Solar energy is one of the major sources of renewable energy. Electrical energy is produced by photovoltaic cells when they allow light particles to knock free electrons from atoms. The amount of electrical output produced by the system is dependent on amount of solar energy received by PV cells. To increase solar energy output, a fixed solar panel inclined towards the optimal point is usually used. The collection of solar energy is increased by using solar tracking systems i.e. single axis or dual axis, which continuously track the sun using incidence angle of sunlight. The analysis is carried out to compare the performance between tracking and non-tracking photovoltaic systems. Data of specific solar panel systems is analysed and compared with simulations and actual outputs to compute performance ratios and deduce conclusions. The average performance ratio is found out to be 0.73 for non-tracking system and 0.90 (17% more than non-tracking systems) for tracking systems. The accuracy of estimated output of a PV system can be improved by using more accurate solar irradiance data, accurate weather conditions, exact system losses and matched inverter efficiency. The efficiency of a PV system can be improved by using solar trackers, using more efficient solar panels, installing them in a less shaded area, cleaning the panels on regular intervals, and using more efficient electrical components.

Key words: Solar system; Solar power; Renewable energy; Photovoltaic; Tracking system; Non-tracking system; Data analysis.

INTRODUCTION

The analysis is carried out to compare the performance between tracking and non-tracking photovoltaic systems. A tracking system tracks the movement of the sun which ensures the maximum sun intensity on the solar panel surface. Meanwhile, non-tracking photovoltaic systems stays fixed at one position. Simulations and actual outputs were compared to deduce the conclusion and improvements suggested.

Objectives

- Developed an understanding of tracking and non-tracking photovoltaic systems
- Studied and explained the grid connected system
- Evaluated Fronius data using calculations of both systems to compare with each other
- Suggested methods to improve performance

LITERATURE REVIEW

Theoretical Background

The renewable electricity generation in the second quarter of 2020

was 30.1 TWh, as compared to the 27.0 TWh generated in the second quarter of 2019, resulted in an increase of 12 % [1]. Small scale generators installed capacity shows that there were over 1 million installations by the end of second quarter of 2020.

Essentially, a Photovoltaic (PV) cell is a panel that can be installed on the roofs of homes and offices. They convert sun light energy into electric energy for domestic and industrial usage. This gives us an advantage of avoiding by-products of the using fossil fuels that ultimately damage the global environment.

Related Research

Evidently, there is a great improvement in the performance of the system when tracking system is chosen over the non-tracking system. Efficiency increases from 25% to 71% when tracking system is used [2,3]. Although there are situations where tracking system cannot be utilised such as huge building's facade.

Tracking systems give the advantage of increased average output, but it also cost more [4]. Furthermore, electrical drives consume great amount of energy from the panels and therefore efficient motors must be used [5]. Using highly efficient motors can increase the cost of the system considerably. There are other ways to improve

*Correspondence to: Muhammad Danial Khilji, MSc Applied Data Sciences, University of Central Lancashire, United Kingdom, Tel: +447460638385; E-mail: danielkhilji@yahoo.com

Received: December 28, 2020; Accepted: February 08, 2021; Published: February 15, 2021

Citation: Khilji M D (2021) Analysis Photovoltaic System in Relation to Tracking and Non-Tracking System. J Fundam Renewable Energy Appl 11:2. doi: 10.4172/20904541.1000284

Copyright: ©2021 Muhammad Danial Khilji. This is an open access article distributed under the term of the Creative Commons Attribution License, which permits unrestricted use, distribution, and reproduction in any medium, provided the original work is properly cited.

performance of the system namely using techniques like Maximum Power Point Tracking [6,7]. Taking voltages between 9AM to 4PM, it was figured out that there is a considerable difference in power output, between tracking and non-tracking systems, at early day time and after roughly 3PM [8]. There was a difference of only 5-10% in the midday.

The performance ratio of the dual axis tracking system is evidently higher as compared to the fixed one. For dual axis system in Tunisia, performance ratio is 0.87 in comparison with Germany, which has ratio of 0.67 for fixed system [9]. There is also a factor of degradation rate of system. Solar tracker can guarantee up-to 80% of power output for at least first 25 years [10].

METHODOLOGY

Dividing project into smaller portions helped identify methodologies easily. The first step was to visualize the Fronius dataset in the MATLAB. The second step is to estimate the difference between tracking and non-tracking system datasets using simulations from MATLAB and PVWATTS. This simulation datasets are then compared with the Fronius dataset.

A case study was then carried out to understand the integrated system that explains how photovoltaic cells convert sun light into electricity. The system is connected to the main grid using the grid connected system. Lastly, the conclusion is made, and improvements are suggested.

DATA ANALYSIS

The University of Central Lancashire provided with their Fronius Solar Panel system dataset of year 2018 which consisted of two inverters namely IG60(1)(#1) and IG60(2)(#2). Their outputs in kWh were provided for each day of year 2018. To visualise the data, the sum of both inverter's outputs was added, and monthly averages were calculated as well as their individual monthly outputs were compared in Figure 1. Then these averages were used to generate a pie chart in MATLAB.

From the pie chart, it is evident that maximum output was generated in the summer season. Alternatively, the least amount of output was in the winter season. The dominating factor for the variation of the output is the weather change over the year. In the North-Western England, most of the days are filled with clouds in winter. The performance ratios are 0.46 and 0.47 for IG60(1)(#1) and IG60(2)(#2) respectively producing total of 0.93. On monthly comparison, they look same visually but on close inspection IG60(2)(#2) produced comparatively higher output shown in Figure 2.

MODEL SIMULATION

To measure the amount of light on the solar panel, Solar Irradiance is used. It is an amount of sunlight energy on the surface of one square meter for one second [11]. At any given time of the day, it is influenced by angle between sunlight and panel surface, distance between source and the panel surface and atmospheric conditions [7]. The solar irradiation on the panel surface heats up the cell temperature hence power output is proportional to the solar irradiation. First step is to calculate operating temperature of the cell.

$$T_{cell} = T_a + \frac{G_a}{G_{STC}} (T_{cell,NOC} - T_{a,NOC}) \times 0.51$$

Where, T_{cell,NOC} (assumed here to be 43oC) [12] is Nominal

Operating Conditions cell temperature, T_a is Ambient temperature and G_a is ambient irradiation power density. This T_{cell} is then used to calculate maximum array power point power PMPP.

$$P_{MPP} = P_{rated} \times \frac{G_a}{G_{STC}} \times (1 + (T_{cell} - T_{m,STC})\alpha_p) \text{ (kW)}$$

Where $\alpha_p = -0.47\%/oC$ is Power temperature coefficient, G_{STC} = 1000W/m², T_{m,STC} = 25 oC, G_{NOC} = 800 W/m², T_{a,NOC} = 13.6oC. Prated is the panel rated power in kWp. Adding degradation factor with rate of 0.8 per annum:

$$P_{PVSystem} = P_{MPP} \times 0.95 \times d^{year} \text{ (KW)}$$

Where degradation rate d = 1-0.008 = 0.992 for UCLAN Fronius system. This calculation is only applicable for first 25 years. Finally, energy generation of system is calculated as:

$$\frac{E_{gen}}{month} = P_{PVSystem} \times No \text{ of hours (kWh)}$$

The PVWatts model was also used to simulate Fronius system. MATLAB mathematical simulation model output is shown in Table 1. To make model as precise as possible, location was chosen as Preston, system losses of total 9% were added, and all other specifications were set according to the Fronius system manual. The list of specifications and their respective results are shown below in Tables 2-5.

INTEGRATED SYSTEM CASE STUDY

The purpose of the case study is to understand the current state-of-the-art integrated systems. This helps us find the issues in the current systems. There are several differences between each solar system. Major ones include difference between tracking and non-tracking systems. Other differences include number axis with allowed rotations and weather a system is an open-loop or a closed-loop.

One of the major problems faced is a shadow over the panels. This shading can be due to panels installed close together or at flat surfaces. There might be another building which block radiation at some specific time of the day or due to trees. Losses due to obstacles can reduce output between 4-20% [9]. Besides these problems, natural factors like cloudy weather will also reduce the average output.

There were major system failures in Germany every 4.5 years with greater number of failures in the following years [9]. This type of failure can cause performance ratio to decrease to zero. These problems can be reduced for optimum performance by carrying out periodic maintenance checks. Automatic switches can be used to avoid islanding hence ensuring safety of the workers. Other factors like weather conditions cannot be eliminated but they can be reduced by placing panels in an environment which have least cloudy weather and minimum shadow in a day.

GRID CONNECTED SYSTEM

To connect a Photovoltaic system to the main grid shown in Figure 3 below, we need to convert Direct Current (DC) voltage to the Alternating Current (AC) voltage and increase the voltage because the voltage from the PV system is 12V-24V and voltage in grid is 220V-240V (220V in UK national grid). We use a system called

Table 1: MATLAB mathematical simulation model output

Month	Average Temperature (C)	Average Solar irradiance per day (kW/m ² /day)	Energy Generated for Non-Tracking (kWh)	Energy Generated for Tracking (kWh)
January	3	0.99	232	314.6
February	3.3	2.08	441.4	596.2
March	5.5	2.99	782.7	939.9
April	7.9	4.94	1216.2	1487.1
May	11.1	5.88	1521.4	1803.5
June	14.2	5.72	1405.3	1674.6
July	11.5	5.20	1426.9	1592.1
August	15.1	5.83	1268.6	1455.4
September	13	3.84	936.1	1130.4
October	10.1	2.28	579.3	702.5
November	6.1	1.35	309.5	409.7
December	3.9	0.82	189.9	269.6

Table 2: Non-tracking PVWatts simulation specifications.

Location and Station Identification	
Requested Location	Preston, Lancashire, PR1 2HE
Weather Data Source	(INTL) AUGHTON, UNITED KINGDOM 17 mi
Latitude	53.55° N
Longitude	2.92° W
PV Systems Specifications (Residential)	
DC System Size	10.8 kW
Module Type	Standard
Array Type	Fixed (roof mount)
Array Tilt	20°
Array Azimuth	180°
System Losses	5%
Inverter Efficiency	96%
DC to AC Size Ratio	1.2
Economics	
Average Retail Electricity Rate	No utility data available
Performance Metrics	
Capacity Factor	10.7%

Grid Tie Inverter (GTI) which makes it possible to connect PV system to the main grid [13,14].

First stage in the grid-tie inverter is a DC-DC converter. In this stage, a low DC voltage from source is converted to the high DC voltage level. Basic DC-DC converter either increases the voltage level or decreases the voltage level depending on the topology used. The boost converter is a type of DC-DC converter which increases the DC voltage.

The next stage in the GTI is to transform the high DC voltage (310V) to the high AC voltage to match it with the voltage of main grid and to supply to the homes. It can be done by either Half Bridge converter or Full Bridge converter which is more efficient. The switches are turned ON and OFF alternately to produce the output and diodes ensure the change in the direction of the current every half cycle [15].

The output voltage from the DC-AC converter is not a perfect sine

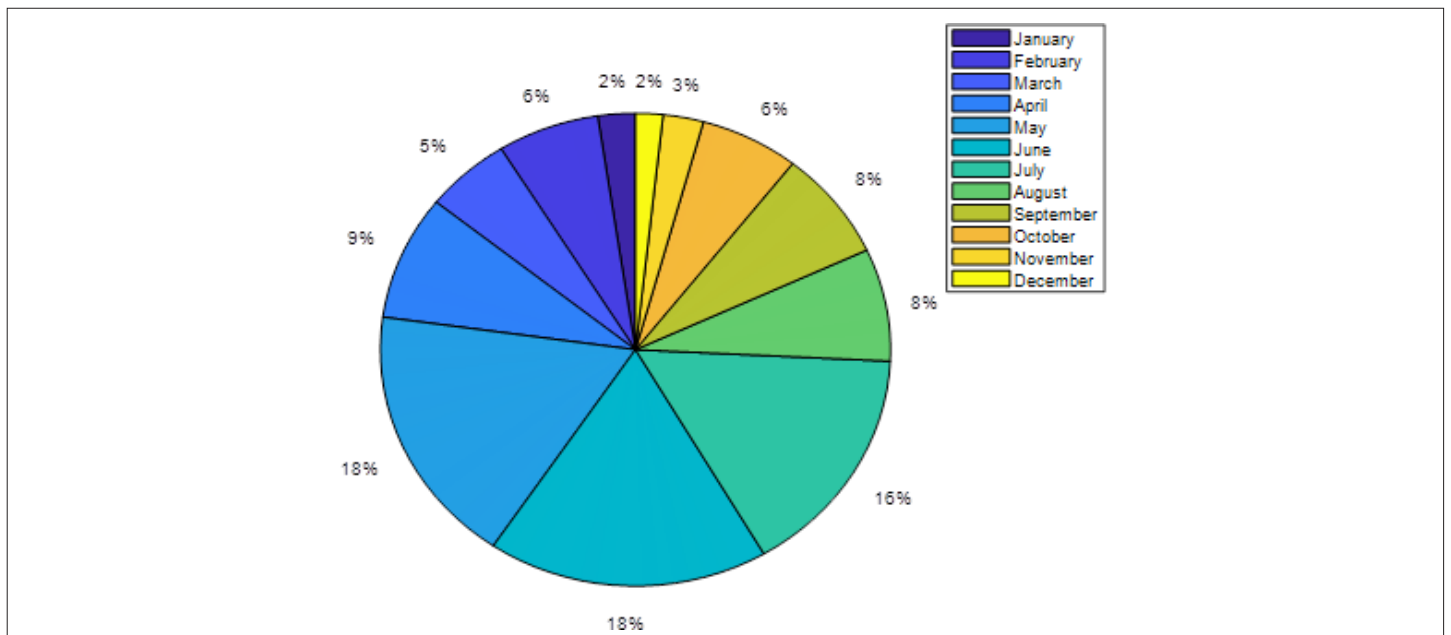

Figure 1: Total monthly output pie chart of Fronius data.

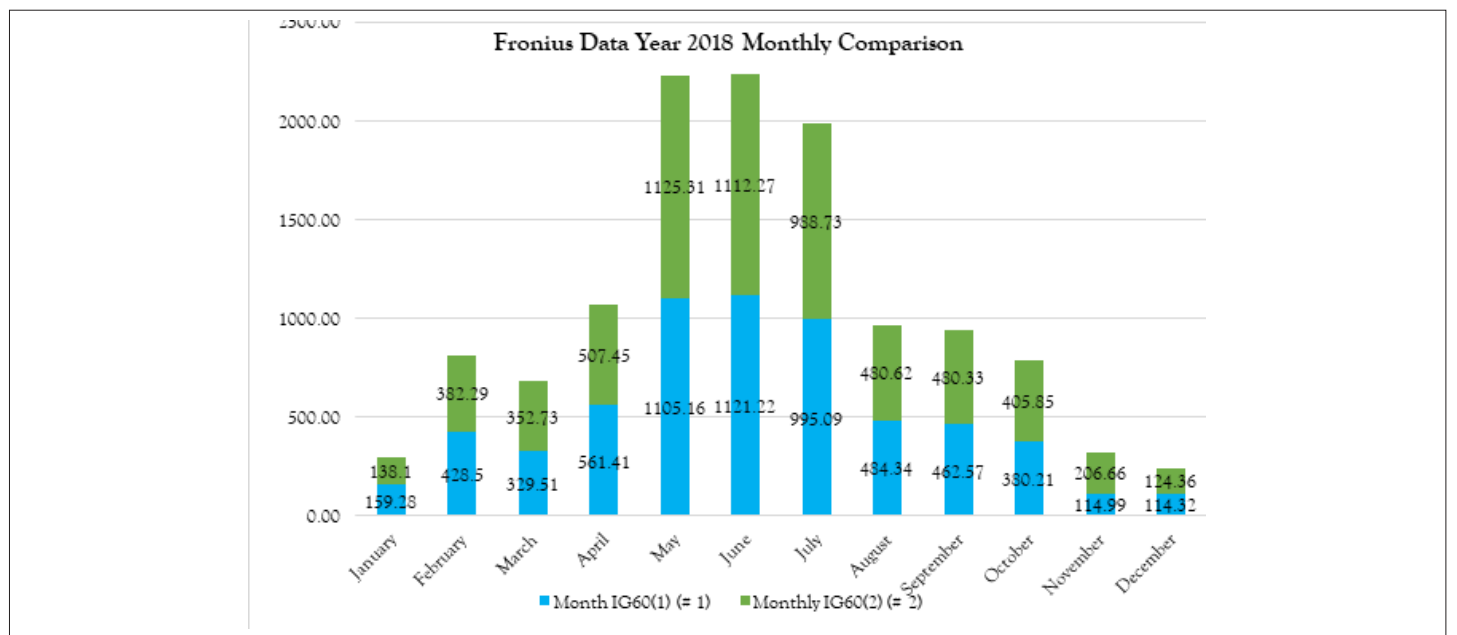

Figure 2: Comparison between outputs of each inverter for each month.

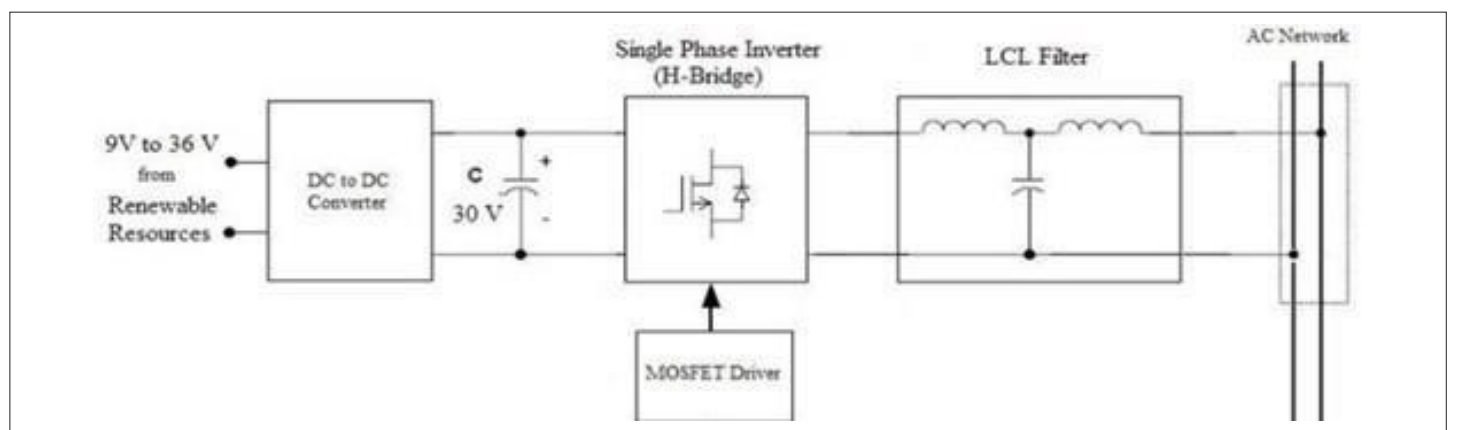

Figure 3: Basic diagram to connect solar panel system to the main grid.

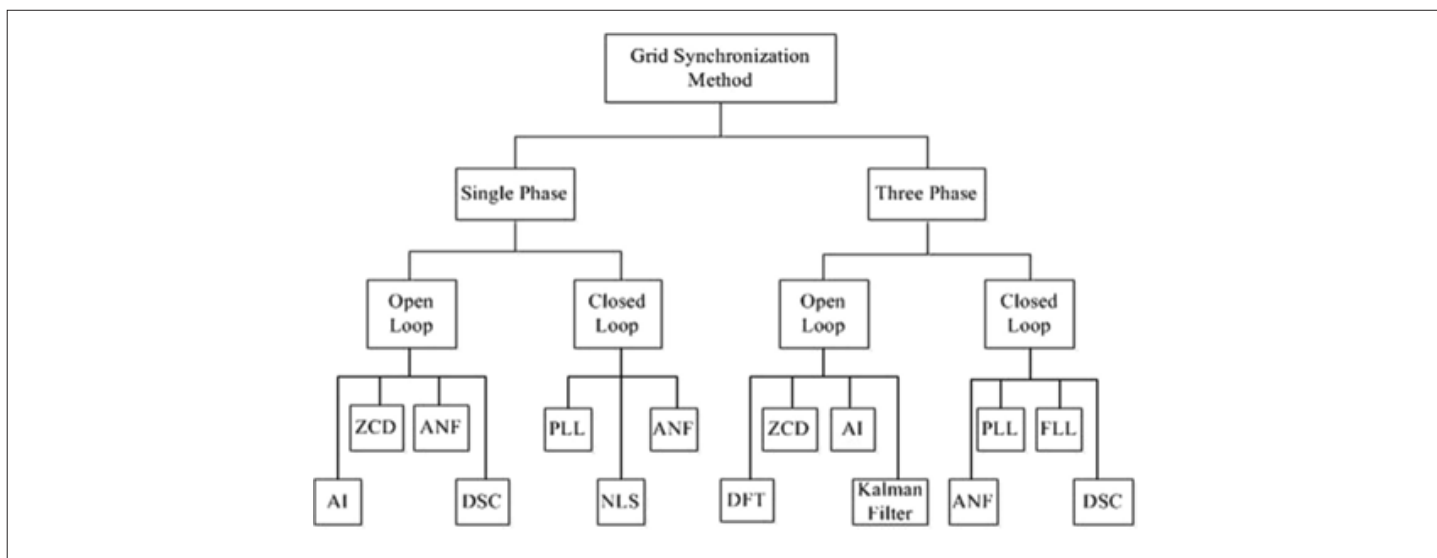

Figure 4: Various grid synchronization methods under respective categories.

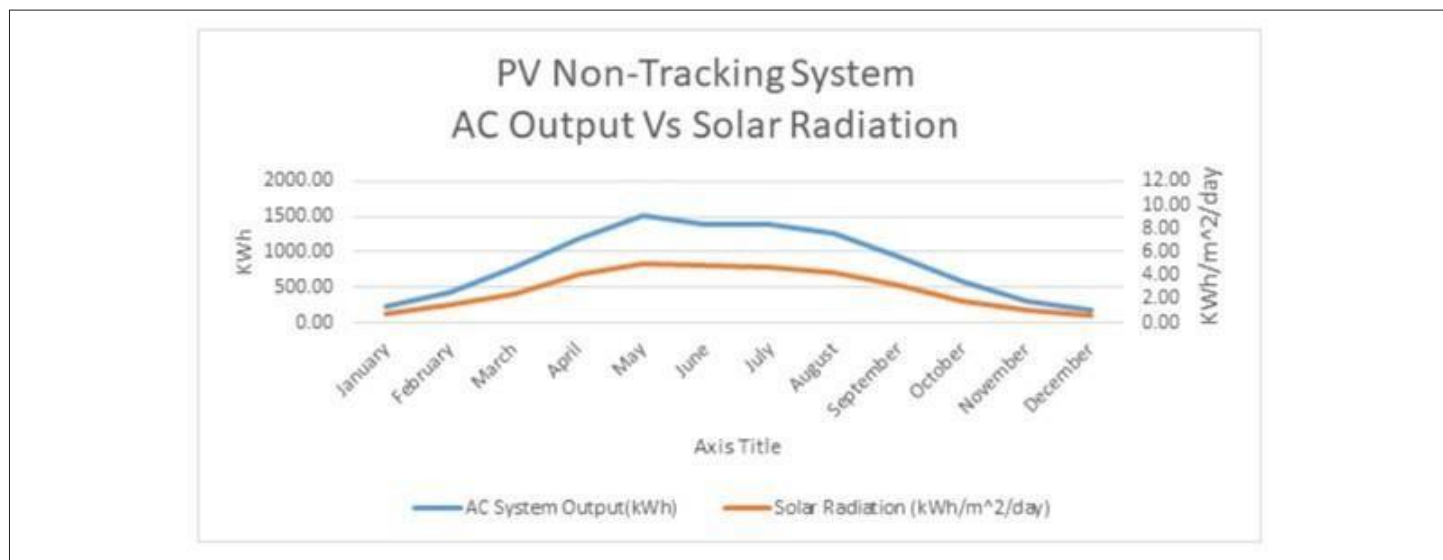

Figure 5: PVWatts Non-tracking system AC output (blue line) vs Solar Radiation (red line).

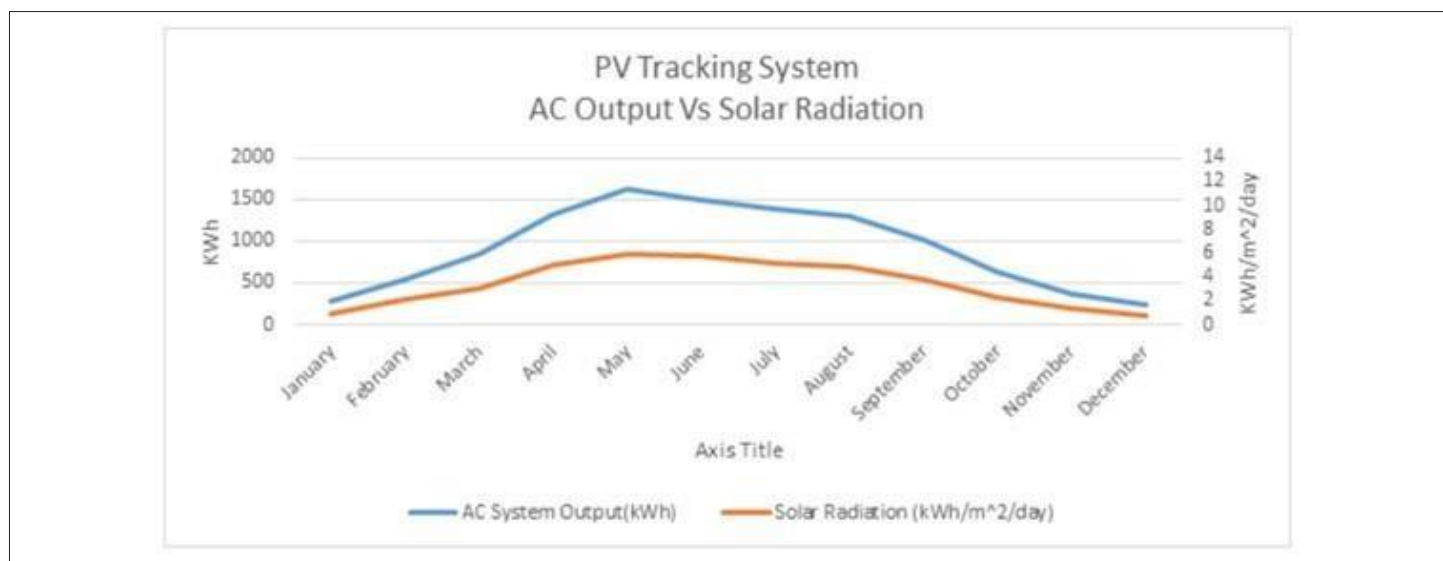

Figure 6: PVWatts Tracking system AC output (blue line) vs Solar Radiation (red line).

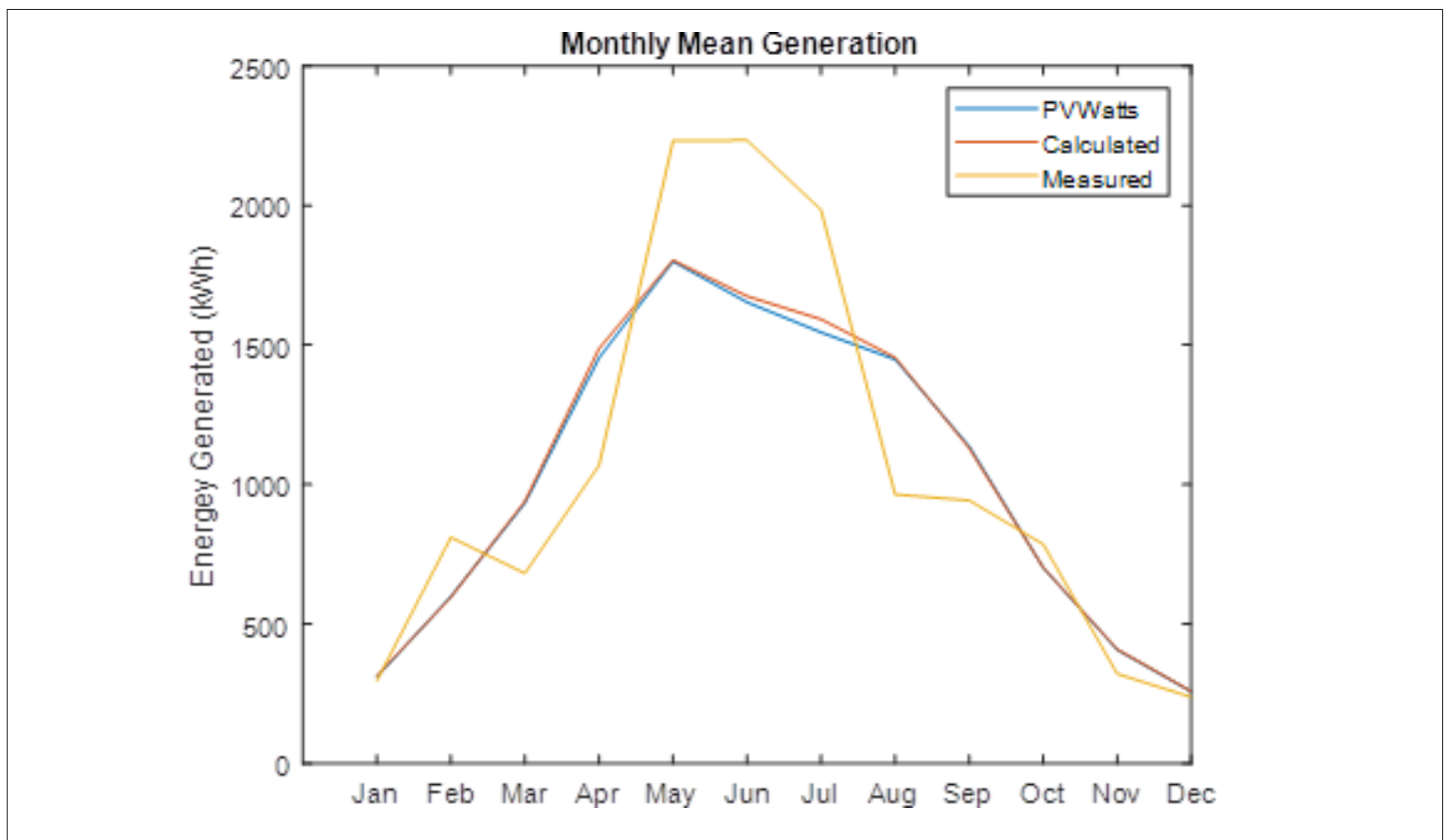

Figure 7: Comparison of mean output for each month between Fronius data (orange line), MATLAB simulation model (red line) and PVWatts simulation model (blue line).

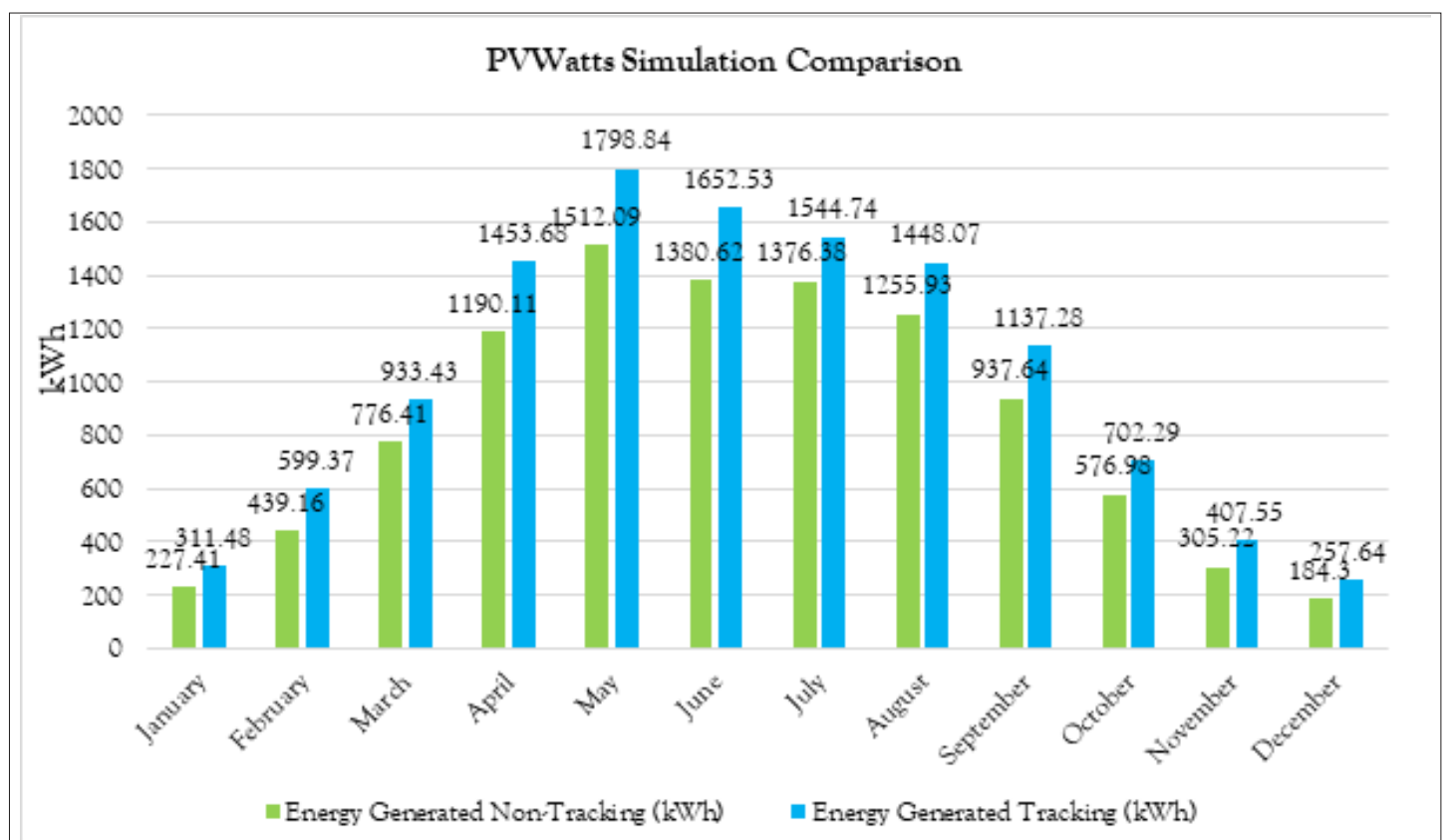

Figure 8: PVWatts simulation model comparison between tracking and non-tracking output.

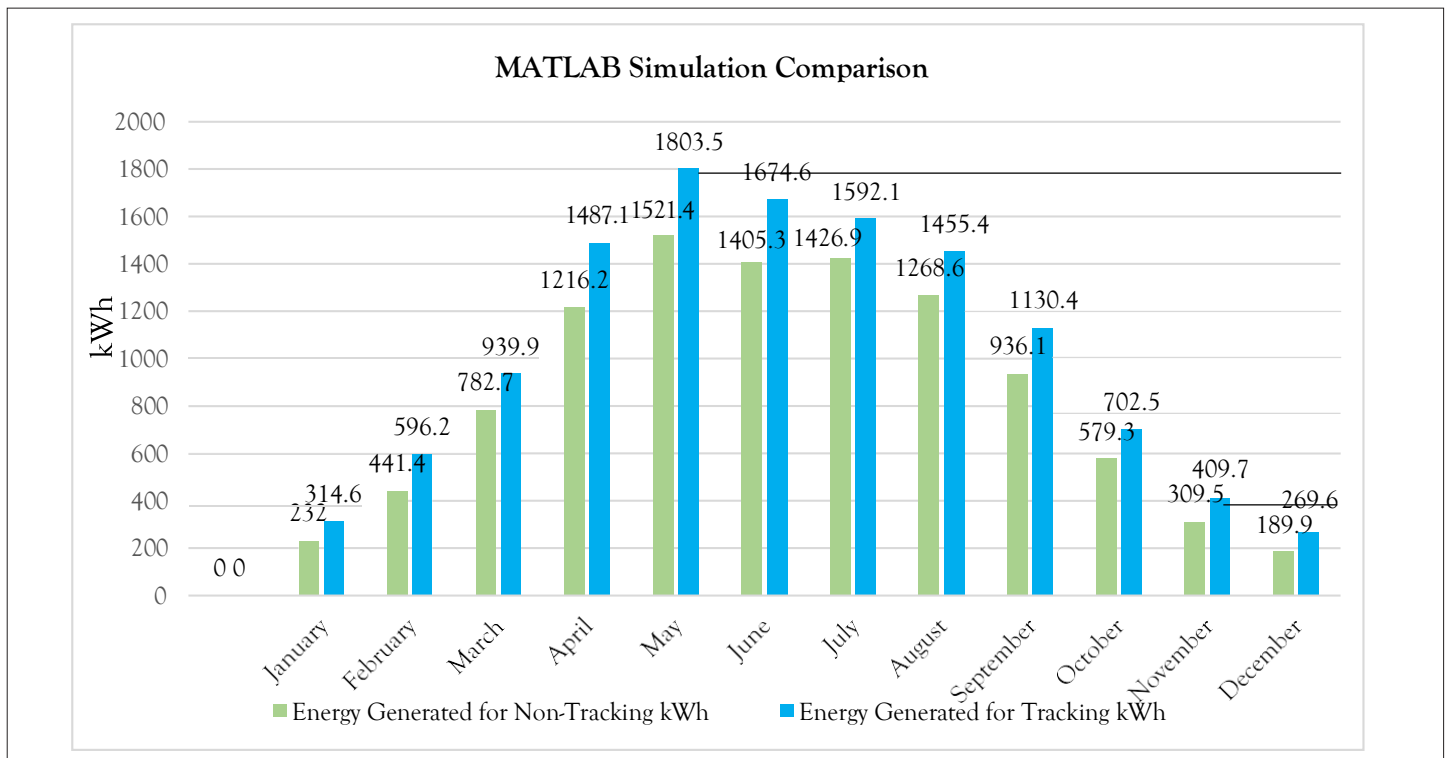

Figure 9: MATLAB simulation model comparison between tracking and non-tracking output.

Table 3: Non-tracking PVWatts simulation output.

Month	AC System Output (kWh)	Solar Radiation (kW/m ² /day)	Plane of Array (W/m ²)	DC Array Output (kWh)
January	227.41	0.73	22.71	246.55
February	439.16	1.54	43.08	465.19
March	776.41	2.49	77.11	816.98
April	1190.11	4.04	121.06	1246.53
May	1512.09	4.96	153.70	1583.14
June	1380.62	4.80	144.04	1446.53
July	1376.38	4.66	144.39	1442.44
August	1255.93	4.21	130.60	1315.45
September	937.64	3.18	95.43	983.66
October	576.98	1.88	58.28	609.61
November	305.22	1.02	30.60	326.65
December	184.30	0.60	18.61	201.61
Total	10162.26	34.11	1039.61	10684.34

Table 4: Tracking PVWatts simulation specifications.

Location and Station Identification	
Requested Location	Preston, Lancashire, PR1 2HE
Weather Data Source	(INTL) AUGHTON, UNITED KINGDOM 17 mi
Latitude	53.55° N
Longitude	2.92° W
PV Systems Specifications (Residential)	
DC System Size	10.8 kW
Module Type	Standard
Array Type	2 Axis-Tracking
Array Tilt	0°
Array Azimuth	0°
System Losses	5%
Inverter Efficiency	96%
DC to AC Size Ratio	1.2
Economics	
Average Retail Electricity Rate	No utility data available
Performance Metrics	
Capacity Factor	12.9%

Table 5: Tracking PVWatts simulation output.

Month	AC System Output (kWh)	Solar Radiation (kW/m ² /day)	Plane of Array Irradiance(W/m ²)	DC Array Output (kWh)
January	311.48	0.99	30.54	332.97
February	599.37	2.08	58.24	631.09
March	933.43	2.99	92.65	982.36
April	1453.68	4.94	148.09	1531.17
May	1798.84	5.88	182.38	1891.47
June	1652.53	5.72	171.49	1731.26
July	1544.74	5.20	161.23	1617.83
August	1448.07	4.83	149.87	1516.54
September	1137.28	3.84	115.18	1191.63
October	702.29	2.28	70.72	739.24
November	407.55	1.35	40.50	432.08
December	257.64	0.82	25.41	276.61
Total	12246.90	40.92	1246.31	12874.25

wave reducing efficiency considerably. Therefore, filtering circuit is used to filter the AC voltage removing any unwanted noise and unnecessary harmonic components that reduces the Total Harmonic Distortion (THD) [16].

The last stage is to synchronize the output of GTI to match with the phase and voltage of main grid [17]. In ideal scenario, voltage parameters of inverter are same as that of main grid and if there is any mismatched then it is fixed within few cycles. It can be done using several techniques developed over time as shown below in Figure 4 [18].

To control the inverter switches, generally microcontroller is used as it can be controlled precisely according to the required output. For inverters, any 32-bit microcontroller can be used. Using microcontroller for tracking can increase output up-to 19.73% [19].

RESULTS

The non-tracking result of PVWatts shows in Figure 5 is a considerable difference between solar radiation and the final AC output. It is predominantly due to system losses. In the peak month of May, there is a wide gap in the input and output whereas in December, there is a very minute difference, but the percentage loss is approximately close to that of May.

Similarly, the tracking system results shows in Figure 6 is a more linear output graph with lesser difference between input and output. It is majorly due to the tracking ability of the system which causes the system to generate higher output per day even in the winter season.

The Figure 7 shows comparison between Fronius system, PVWatts and mathematical model in MATLAB. Theoretically, simulations results must show higher output, but it is not so specifically in the May to July time. The reason behind is that PVWatts shown in Figure 8 and MATLAB shown in Figure 9 take average of number of years. There might be years with more cloudy days which ultimately bring the average output below. Meanwhile, Fronius graph shows result of only year 2018. Furthermore, the simulations have considered all the possible losses that add up to 9% in total. The performance ratios of MATLAB are 0.91 and 0.74 for tracking and non-tracking, respectively.

CONCLUSION

Due to global warming, Solar Panel system technology is advancing rapidly since the last decade. There have been many advances in the solar panel systems and different solar panel systems can now be classified according to their driving methods. Clearly, tracking system advantages outweighs its disadvantages hence it is much better than non-tracking system. There is still a great room for improvement specifically for the solar panel. Its efficiency is between 15 to 22% that reduces the final output greatly. Periodic maintenance checks must be carried out to ensure maximum efficiency. Solar Panels must be cleaned with pressure air to eliminate dust and light weight motors must be used for tracking as they use less energy to rotate panel.

REFERENCES

1. Energy Trends September 2020. <https://www.gov.uk/government/statistics/energy-trends-September-2020>.
2. Rizk J, Chaiko Y. Solar tracking system: more efficient use of solar panels. *World Academy of Science, Engineering and Technology*. 2008; 41:313-315.
3. Khadidja B, Dris K., Boubeker A, Nouredine S. Optimisation of a solar tracker system for photovoltaic power plants in Saharian region, example of Ouargla. *Energy Procedia*. 2014; 50:610-618.
4. Koussa M, Cheknane A, Hadji S, Haddadi M, Nouredine S. Measured and modelled improvement in solar energy yield from flat plate photovoltaic systems utilizing different tracking systems and under a range of environmental conditions. *Applied Energy*. 2011; 88:5:1756-1771.
5. Seme S, Štumberger B, Hadžiselimović M, Sredenšek K. Solar Photovoltaic Tracking Systems for Electricity Generation: A Review. *Energies*. 2020;13:16:4224.
6. Mazaheri Salehi P, Solyali D. A review on maximum power point tracker methods and their applications. *Journal of Solar Energy Research*. 2018; 3:2:123-133.
7. Naamandadin NA, Ming CJ, Mustafa WA. Relationship between Solar Irradiance and Power Generated by Photovoltaic Panel: Case Study at UniCITI Alam Campus, Padang Besar, Malaysia. *Journal of Advanced Research in Engineering Knowledge*. 2018; 5:1:16-20.
8. Hesari S. Design and implementation of maximum solar power tracking system using photovoltaic panels. *International Journal Of Renewable Energy Research*. 2016; 6:4:1221-1226.
9. Duffie JA, Beckma WA, Blair N. *Solar engineering of thermal processes, photovoltaics and wind*. John Wiley & Sons. 2020.
10. Jordan DC, Kurtz SR, Vansant K, Newmiller J. Compendium of photovoltaic degradation rates. *Progress in Photovoltaics: Research and Applications*. 2016; 24:7:978-989.
11. SOLAR IRRADIANCE. 2008. Available: nasa.gov/mission_pages/sdo/science/Solar%20Irradiance.html.
12. Wood A, Miller A, Mcnab SJ, Lemon S. The EECAenergywise (TM) PV Solar Calculator. *Power and Energy Systems Engineering*. 2017.
13. Abdar HM, Chakraverty A, Moore DH, Murray JM, Loparo KA. Design and implementation a specific grid-tie inverter for an agent-based microgrid. *IEEE Energytech*. 2012; 1-6.
14. Narendiran S. Grid tie inverter and MPPT-A review, 2013 International Conference on Circuits, Power and Computing Technologies (ICCPCT). *IEEE*. 2013; 564-567.
15. Cemal Keles BB, Akcin M, Kaygusuz, Karabiber AA Photovoltaic System Model For Matlab/Simulink Simulations. 4th International Conference on Power Engineering. 2013.
16. Williams D. Understanding, Calculating, and Measuring Total Harmonic Distortion (THD). Available: *Understanding, Calculating, and Measuring Total Harmonic Distortion (THD)*. 2017.
17. Sondawale SR, Jagtap PP, Tarnekar SG. Design and Implementation of Single Phase Grid Tie Inverter. 2nd International Conference on the Developments in Renewable Energy Technology (ICDRET), 2012.
18. Jaalam N, Rahim NA, Bakar AA comprehensive review of synchronization methods for grid-connected converters of renewable energy source. *Renewable and Sustainable Energy Reviews*. 2016; 59: 1471-1481.
19. Das S, Chakraborty S, Sadhu PK, Sastry OS. Design and experimental execution of a microcontroller (μ C)-based smart dual-axis automatic solar tracking system. *Energy Science & Engineering*. 2015; 3:6: 558-564.