

## Central Lancashire Online Knowledge (CLoK)

Title	Advances in Sensing for Real-Time Monitoring of Tribological Parameters
Type	Article
URL	<a href="https://clock.uclan.ac.uk/49150/">https://clock.uclan.ac.uk/49150/</a>
DOI	##doi##
Date	2023
Citation	Liskiewicz, Tomasz, Sherrington, Ian orcid iconORCID: 0000-0003-1283-9850, Khan, Thawhid and Liu, Yanfei (2023) Advances in Sensing for Real-Time Monitoring of Tribological Parameters. Tribology International, 189 . ISSN 0301-679X
Creators	Liskiewicz, Tomasz, Sherrington, Ian, Khan, Thawhid and Liu, Yanfei

It is advisable to refer to the publisher's version if you intend to cite from the work. ##doi##

For information about Research at UCLan please go to <http://www.uclan.ac.uk/research/>

All outputs in CLoK are protected by Intellectual Property Rights law, including Copyright law. Copyright, IPR and Moral Rights for the works on this site are retained by the individual authors and/or other copyright owners. Terms and conditions for use of this material are defined in the <http://clock.uclan.ac.uk/policies/>

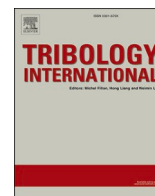

## Advances in sensing for real-time monitoring of tribological parameters

T. Liskiewicz<sup>a,\*</sup>, I. Sherrington<sup>b</sup>, T. Khan<sup>a</sup>, Y. Liu<sup>c</sup>

<sup>a</sup> Department of Engineering, Faculty of Science and Engineering, Manchester Metropolitan University, Manchester M1 5GD, UK

<sup>b</sup> Jost Institute for Tribotechnology, University of Central Lancashire, Preston PR1 2HE, UK

<sup>c</sup> School of Mechanical Engineering, Beijing Institute of Technology, Beijing, 100081, China

### ARTICLE INFO

#### Keywords:

Tribotronics  
Industry 4.0  
Digital  
Data

### ABSTRACT

The wider availability of low-cost sensing and data acquisition technologies means that real-time sensing of tribological parameters is becoming increasingly viable. Consequently, the potential to use these technologies to monitor in-service tribological components has increased significantly. This paper presents a review of a number of state-of-the-art in sensors for measuring friction, wear and lubricant properties. It also elaborates on the use of sensor coatings as an emerging area for directly probing the tribological interface. It is concluded that sensors will find ever increasing uses in condition monitoring applications. However, sensing and tribology is beginning to evolve towards “Tribotronics” where combining the sensing of machine elements that have conventionally been passive with computational capability, or even embedded intelligence, along with actuation can create active machine elements, optimised to operate with say minimum power loss in all situations of duty. Additionally, it is noted that by incorporating sensing and responsive capabilities, functional surfaces can also become part of a bigger connected systems particularly in association with Industry 4.0. Increased use of sensors in tribological components alongside machine learning and artificial intelligence, will also support the shift in industrial tribological analytics.

### 1. Introduction

Tribology is recognised as a highly interdisciplinary subject bringing together several research fields including mathematics, engineering, chemistry, physics and materials science. This combination helps tribology to extend beyond the realm of mechanics and have an influence on areas such as emissions, healthcare and sustainability [1]. Even with its worldwide industrial impact, the word “tribology” is not well-known. Ciulli [2] believes this is due to the limited diffusion of linking the name tribology to friction and wear problems. However Popov [3] believes a ‘golden age’ of tribology will be realised with the development of new research areas, particularly with increasing demands from high-performance machinery since modern society continuously expects greater functionality, reliability, efficiency and longer lifetimes from all machine components.

Tribological concepts have evolved with time from pre-history to the modern era. A historical evolution of tribology from before and through the industrial revolutions has been reported by Frene et al. [4], Dowson [5], Bartz [6] and Ciulli [2].

Tribological practices have been successfully implemented into the

design specifications of critical machine elements, helping to improve their performance and durability whilst achieving significant economic savings in relation to energy and material consumption. The impact of tribology can be illustrated by many examples of machine development. For example, hydraulic motors which have seen a fivefold reduction in weight over 30 years without compromising on output performance [7]. Industry sees a continuous trend towards more compact mechanical systems and components whilst pushing for higher power densities. To achieve this, innovative solutions in the design and operation of tribological contacts must be constantly investigated. Current tribological contact performance is now approaching limits as most machine elements are passive constrained by geometry, materials and lubricant properties with pre-set capability, designed to perform in a specific fashion under a range of operating conditions. To improve the performance of tribological contacts it has been proposed that operating state of machine elements could be modified in service using a concept termed “Tribotronics” [7].

Tribotronics is a term initially coined at Luleå University of Technology in 2008 [7]. It involves the integration of tribology and electronics to form smart active tribological systems which utilise

\* Corresponding author.

E-mail address: [t.liskiewicz@mmu.ac.uk](mailto:t.liskiewicz@mmu.ac.uk) (T. Liskiewicz).

<https://doi.org/10.1016/j.triboint.2023.108965>

Received 14 March 2023; Received in revised form 28 July 2023; Accepted 16 September 2023

Available online 18 September 2023

0301-679X/© 2023 The Author(s). Published by Elsevier Ltd. This is an open access article under the CC BY license (<http://creativecommons.org/licenses/by/4.0/>).

modelling, sensors and actuators to dramatically improve performance. Tribotronics are similar to mechatronic systems. However, the latter uses information from inputs or useful outputs of a mechanical system (torque, rotational speed, load etc.) to control its operation [8]. Tribotronics utilises additional so-called “loss outputs” such as vibration, wear, friction, etc. as feedback data to improve efficiency and performance of the machinery [7]. This requires active condition monitoring of a tribological system, where autonomous and self-adjusting algorithms apply corrective actions through actuation to achieve best performance [9].

This paper reflects on a state-of-the-art in sensor technologies for measuring friction, wear and lubricant properties which have potential for use for condition monitoring and use in tribotronic systems. It closes by summarising observations and by suggesting possible future trends for tribology and Tribotronics in particular.

## 2. Why probe tribological interface in real-time?

### 2.1. Friction and wear are a system response

During the 1960s, a “round robin” of experimental studies of friction and wear were conducted under the auspices of the OECD. These experiments demonstrated that even in apparently simple metal-to-metal interfaces the reproducibility of friction and wear measurements on controlled systems (in this instance pin-on-disc machines) tended to be very poor [10]. Recognising the issue, further studies, co-ordinated through the Versailles Project on Advanced Materials and Standards (VAMAS), were conducted during the 1980s [11,12]. These latter studies concluded that under more rigorously managed conditions, experimental measurements of friction and wear could be more reproducible. However, the reproducibility of friction data within a laboratory was typically no better than  $\pm 13\%$  and data from several laboratories (inter-laboratory) doing similar tests was only reproducible to around  $\pm 20\%$ . Similar outcomes were found for wear measurements, but with slightly better reproducibility for wear data for a single laboratory. Considerations leading to better reproducibility were reported to be related to several factors, including, choice of test equipment, specimen preparation, operating conditions and environmental conditions.

The results of these investigations demonstrate that even under carefully curated conditions friction and wear data are unstable. This arises because friction coefficients and wear rates are a system response, rather than simply being a materials response. This system response is dependent on many factors including the physical conditions at the interface (e.g., contact conformity, roughness, sliding speed/load, presence of debris, contact temperature), ambient environmental conditions (especially temperature and humidity), interface stiffness, etc. and they require careful management in laboratory investigations to gain reproducible data as they affect the physical phenomena occurring at the interface in a fundamental way.

### 2.2. Scaling to component use

In addition to the considerations of environmental and operating conditions, components in machines operating in the field are subject to additional factors which are generally not reflected in laboratory tests. These include changes in interface contact size due to variable contact pressure, differences in contact repetition rate, the build-up of free and adhered wear debris, contamination from external sources, and corrosion. These factors affect how experimental data needs to be “scaled” to reflect additional “real world” influences when modelling contacts and they introduce further time-based dependences for friction and wear over and above those which may be investigated in laboratory testing. The combination of the dependence of friction and wear on both system parameters and real-life operating conditions, leads to degree of complexity which makes modelling of the tribological behaviour of

machine contacts highly challenging at best and unreliable at worst.

### 2.3. The move to real-time sensing

As reliable modelling of the life and performance of machine components in service is so challenging, if the performance or lifetime of a machine is to be established, it is desirable to measure friction and wear as well as other tribological parameters directly and use this duty data for predictions of future performance. The increasing availability of low-cost sensing and data acquisition technologies means that real-time measurement of these tribological parameters is becoming more viable, and in recent years simple measurement technologies have been integrated into commercially available tribological products. Examples of the latter include rolling element bearings with integrated sensors to measure a range of parameters such as vibration, temperature and speed [13] as well as polymer bearings and chains with wear sensing capability [14,15].

## 3. Probing friction

### 3.1. Measuring force in tribometers

Friction can be measured using a load cell, which is a sensor that converts a load or force acting on it into an electronic signal. Tribometer set-ups consist of a load cell which delivers an output voltage which varies in proportion to the (friction) force so it can be captured by a data logger and transmitted to a PC where it is scaled into a friction force [9]. There are different types of load cells available on the market [16]:

- Resistive load cells – With the application of a force/load/stress to the sensor, the electrical resistance changes. A simple example of a device of this type is a strain gauge in which small changes in the resistance of an array of conductors can be determined using a bridge type amplifier, which presents an output voltage proportional to strain when a force is applied.
- Capacitive load cells – Most commonly, these load cells use the capabilities of piezo electric materials. When a force is applied a differential charge develops at the ends of the piezo-electric material which is proportional to the applied force. This charge can be measured using an appropriate charge amplifier giving an assessment of the applied force.

### 3.2. Measuring cutting forces during machining

One area of engineering in which forces between components are frequently measured is in manufacturing for the assessment of machining and forming tools, work-piece materials and cutting fluids.

Cutting force measurement techniques can be divided into two categories: direct force measurements where the strain due to cutting forces is measured directly on the tool, and indirect force measurements [17], where forces are inferred by fully independent sensors.

#### 3.2.1. Direct methods

- Table dynamometers – Typically these sensors are composed of a thin layer of piezoelectric material assembled between two plates. Piezoelectric sensors can be regarded as under-damped spring mass systems, with a single degree of freedom for each of the measuring axes [18,19]. When these sensors are used it is important to ensure that the rate of drain of charge for measurement is very low to ensure that any static component of force remains apparent in the output signal. Therefore, such sensors are mainly used in dynamic applications where signals change rapidly, and a high frequency bandwidth is required.
- Strain gauges – To achieve measurement accuracy, greater emphasis is required upon measuring the dynamic component of the cutting

force. A strain gauge-based tool dynamometer and a piezo-film accelerometer can be used to detect both dynamic and static cutting forces [20]. Yıldız et al. [21] utilised a dynamometer based on strain gauge and piezo-electric accelerometer to take static and dynamic measurements of multi-axis cutting forces during turning. The sensing system is expensive and has limited bandwidth [22].

- Optoelectronic cutting force sensors – For dynamic machining applications optoelectronic sensing systems which measure deflection using Fibre Bragg Gratings (FBG) can be utilised. FBG sensors utilise wavelength division multiplexing techniques and are applied to the cutting tool surface. The key advantages of optoelectronic cutting force measurement are their wide measurement range, high reliability, low weight and greater adaptability [23].

### 3.2.2. Indirect methods

- Capacitive cutting force measurement – An alternative, less conventional, form of capacitance transducer involves the use of two parallel plates separated by a small distance. The capacitance of such systems depends on the area of the plates, the permittivity of the intervening medium and the separation of the plates. When a force is applied the measurement system outputs can be obtained via capacitive ac-bridges. Albrecht et al. [24] used capacitance displacement measurements as an indirect cutting force sensor (Fig. 1). The sensor was mounted onto the spindle and the gap variation between the spindle shaft and sensor was measured. This gap variation was proportional to the applied cutting force. Drawbacks of this arrangement included complexities related to integration of the sensor system into the machine tool and the impact of intrinsic temperature dependence [24].
- Displacement-based dynamometers – Cutting forces can be measured using a flexure-based dynamometer where flexure displacement is measured, and the force is determined using structural deconvolution. This technique extracts force values by filtering the displacement signal using the flexure's displacement-to-force frequency response. The procedure involves determining the excitation forces through analysing the Frequency Response Function (FRF) using single degree of freedom (SDOF) and multiple degree of freedom (MDOF) flexure-based dynamometers. This is followed by applying

the structural deconvolution technique which involves applying a filter developed on the flexure's inverted FRF to the dynamic displacement measured. From this filtered displacement, dynamic force can be determined [25].

- Motor current measurement – Recent studies have determined cutting forces by detecting the drive motor load (Fig. 2) [17]. Shin et al. [26] utilised current sensors to predict cutting force during end-milling with an acceleration sensor and Hall-effect current sensors. Li [27,28] used inexpensive Hall-effect current sensors and models based on the spindle and feed drive of a turning machine tool to measure three-axis cutting forces. An algorithm was used to predict the tangential and axial cutting forces. These studies showed this method could measure multi-component cutting forces with errors of less than 25%.

### 3.3. Measuring friction during metal forming

In metal forming friction is associated with high pressures, which occur naturally as part of the deformation system.

#### 3.3.1. Direct methods

- Sliding pin sensors – Several studies have utilised pin sensors (Fig. 3a) which were connected to a transducer and implemented within the holes in the work roll [29]. One pin would be mounted radially and the other at a set angle. These pins pressed against load cells within the rolls allow the cutting forces, which act along the line of each pin to be measured. Using mathematical models and assuming low sliding friction between the pins and the die hole, the friction coefficient could be calculated. In similar set-ups the pin has had direct contact with the workpiece surface [30]. The disadvantage of this method is that imprints are produced at the die surface. To measure strains with good accuracy, the sensors require a low stiffness. This leads to a local deformation higher than in the surrounding roll, which is typically stiffer, resulting in friction coefficient deviation in the contact [31].
- Cantilever pin sensors – In this approach, the cantilever frictional force pin sensor (Fig. 3b) is usually in contact with the workpiece surface whilst the rest of the sensor is buried within the die. This allows the normal force and frictional force on the tip to be

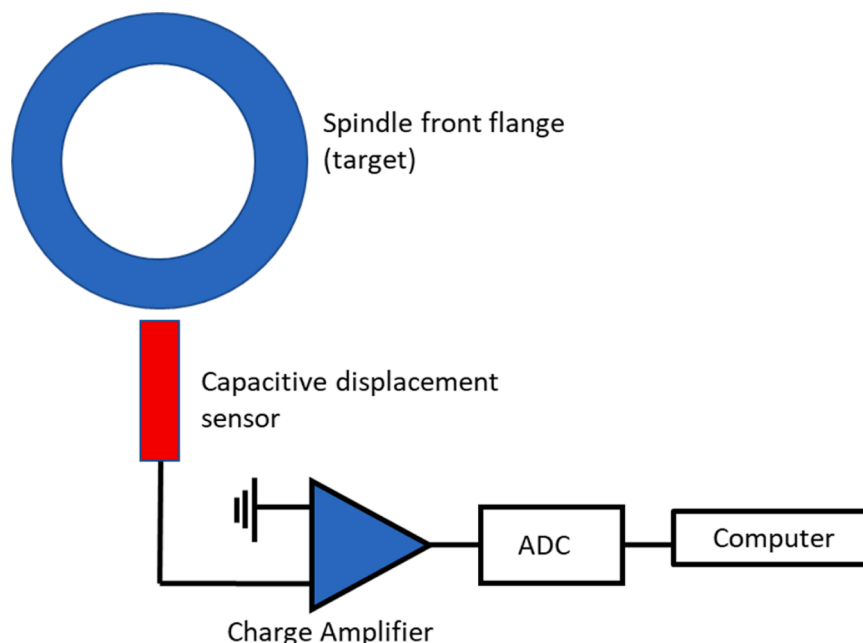

Fig. 1. Spindle integrated displacement sensor system from the top view (after [24]).

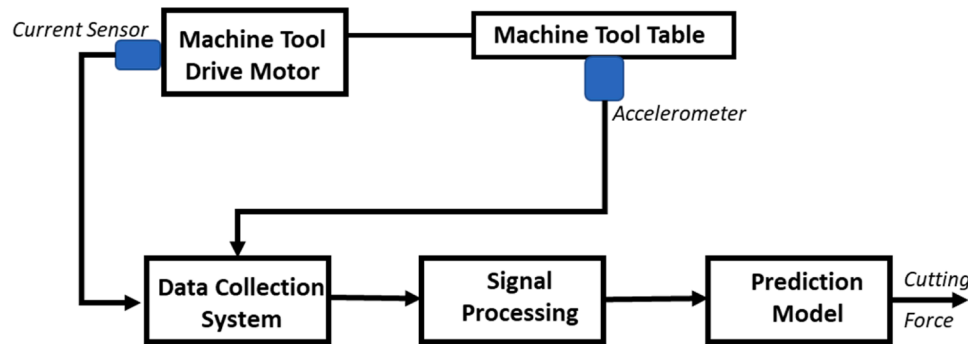

Fig. 2. Schematic illustration of current-sensor-based cutting force sensing technique (after [17]).

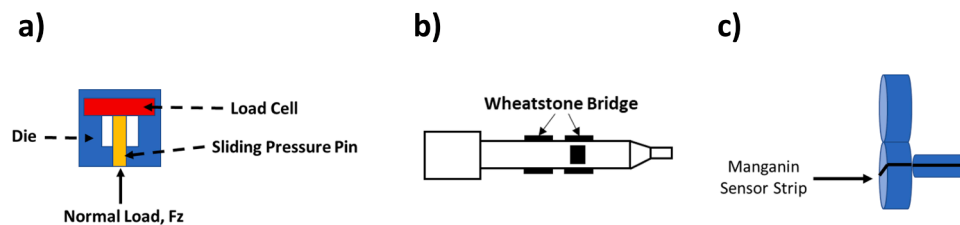

Fig. 3. a) Sliding pin sensor, b) Cantilever pin sensor, c) Manganin line sensor designed by Kannel and Dow (after [32]).

calculated. In this configuration, the sensor works well with the application of low normal pressures. At high normal pressures the workpiece material extrudes and reduces the gap between the pin sensor and workpiece. Due to this extrusion the sensor stops operating and the product is also marked [29].

- Integrated friction sensors – There are several sensor designs which utilise line sensors to measure the friction force across the roll face. Kannel and Dow [32] deposited thin strips of manganin and titanium on the roll face which were then protected by a layer of silica (Fig. 3c). Titanium is affected by temperature but unaffected by pressure. However, for manganin the phenomena are reversed. Temperature measurements were successfully taken during rolling experiments. However, due to the difficulty of separating the normal force from the friction force it was not possible to take pressure measurements.

### 3.3.2. Indirect methods

Indirect friction sensors – The approach involves considering the roll as a sensor. By measuring elastic strains at various positions inside the roll during rolling, friction at the roll-strip can be determined by applying a mechanical inverse analysis or analysing normal and shear stresses at the roll-strip interface. Indirect friction sensors avoid direct contact with the strip, helping to avoid the formation of markings [33].

## 4. Probing surface degradation

Understanding wear behaviour is crucial for material selection and machine element design. Due to the many influencing factors, it is difficult to predict in-situ wear trends, so laboratory-based trials with similar materials and representative contact conditions are carried out. Following the experiments, wear analysis is carried out, with traditional methods including mass-loss measurements. Other analysis techniques involve surface profilometry, where measurements of the surface shape around areas of wear can be registered using image processing techniques then subtracted to estimate the lost material volumes. A key drawback of these approaches, however, is their inability to provide an instantaneous wear rate, only absolute wear volumes and average wear rates can be provided post-test [34].

Other wear measurement techniques include linear potentiometers,

eddy current and laser displacement sensors which can measure position and displacement. These sensors can be mounted at a fixed position allowing the measurement of displacement of the moving component and the inferring of wear measurement by the change in component thickness. Some tribometers have a transducer fitted to measure the vertical movement of the pin component relative to a fixed datum, providing an indication of wear. However, wear debris, thermal expansion and transfer of material can influence the displacement measured and compensation for these effects should ideally be incorporated [35]. Overall, these sensors measure the position of the specimens and allow the net wear of both components to be inferred [34].

The methods of real-time wear monitoring can be classified into direct and indirect. Direct methods might involve using fibre optics or other optical methods, whereas indirect methods measure factors such as vibrations, acoustic emissions (AE), or surface roughness to infer wear [36].

### 4.1. Fibre optical sensors

Fibre optic sensors are used to detect changes in the physical characteristics of surfaces and interfaces. Changes in the output of these sensors can be correlated with the changes in surface physical characteristics using the light transmitted through the optical fibre. This methodology depends on the sensor geometry and measurements of either transmission at an interface or intensity loss. These sensors can establish a relationship between the level of surface degradation and intensity loss as a function of time [37].

There are two broad fibre optic sensor categories: intensimetric and interferometric. Intensimetric sensors are based on the amount of light detected through the fibre. Failure or damage is detected by a break in the fibre that leads to the termination of the light signal to a detector. Optical time domain reflectometry can be utilised to identify the location where the fibre has broken. Intensity variation caused by micro-bending losses are measured by strain sensors, however this technique is deemed inaccurate and insensitive by some investigators [37,38].

### 4.2. Debris monitoring

Four debris features: concentration, morphology, size and

composition can highlight different wear behaviours [39–41]. Debris size and concentration are influenced by the degree of wear and can reflect wear severity and wear rate [39]. The debris size can also help to indicate the type of wear and its morphology is also related to wear type and severity [42].

Particle counters can be utilised to measure particle debris concentration and size [43]. Bowen and Anderson's [42] study investigated the relationship between wear type and debris size. By analysing debris formed from five typical wear types: cutting, rubbing, rolling fatigue, sliding and combined rolling and sliding, they found that the debris size can indicate the wear type with debris over 15  $\mu\text{m}$  being formed by particularly abnormal wear.

Optical methods involving utilisation of a light transmitter and receiver (Fig. 4), where debris blocks the light and the change in light intensity reflects the size of the debris particles, is seen as a sensitive method and can detect debris particles above 5  $\mu\text{m}$  [44–46].

#### 4.3. Acoustic emission

The application of acoustic emission (AE) sensors (Fig. 5) is increasingly popular, partly because it uses very high-frequency signals which reduces its propensity to be interrupted by surrounding noise. AE is a type of transient elastic-wave (stress wave) produced by the release of energy from a localised source within the material [47,48]. With the application of a certain level of stress to a material leads to the rapid release of strain energy in the form of elastic waves which can be detected by transducers. AE signal frequencies are typically within the range of 20 kHz and 1 MHz [49]. Dornfeld [50] highlighted several sources of AE due to the stress waves formed through the deformation of material during metal cutting, including: (a) chip shearing, (b) workpiece plastic deformation during cutting process, (c) flank wear due to the frictional contact between the workpiece and tool flank face, (d) fracture of the tool, and (e) chip breakage. Acoustic emissions from sources (a)-(c) produce continuous AE signals which can be associated with plastic deformation, while sources from (d)-(e) generate transient AE signals.

Attempts have been made to correlate AE signals with wear trends through the varying of statistical AE parameters in dry sliding conditions. McBride et al. [51] study suggested that AE signals characterised by high amplitude, correlated with material removal, whereas running-in wear and plastic flow correlated with lower amplitude (longer rise time signals). Jiaa and Dornfeld [52] [13], found that with sliding metal-on-metal contacts, the AE signals correlated with different wear mechanisms and AE root mean square (RMS) signals. They also suggested that by analysing the frequency domain of the raw AE signal the possibility of stick-slip in a sliding contact could be detected. Additionally, Hanchi and Klamecki's [53] study demonstrated that the transition of the wear rate from mild to severe during dry sliding was reflected in the variation of AE count rate. It has been suggested that a combination of AE, vibration analysis and chip formations (as described

earlier) could determine tool condition and wear reliably without interrupting the machining process. AE analyses the internal changes of a material (as it contains high frequency components), whilst physical vibrations reflect the external changes (they contain low frequency components) during the machining process, allowing the tool condition to be investigated [47].

#### 4.4. Electrostatic sensing

Electrostatic sensing technology involves monitoring changes in the static charge level within a system which reflects changes in the conditions of the dynamic system, for example the pumping of a highly aerated flow [54,55]. This monitoring system is composed of a passive sensor connected to a charge amplifier with an output voltage signal which can be recorded and processed. When a charged particle passes the electrostatic sensor face, an opposing charge will be induced on the sensor surface. There is a redistribution of electrons in the sensor to balance the presence of additional charge close to the sensor face creating a current flow that can be measured. This technique provides a direct measurement of the volume of debris produced by contact degradation [49,56]. A study by Wang et al. [56] found correlation between specific wear rates of contact materials and electrostatic charge levels (Fig. 6).

#### 4.5. Ultrasonic sensors

Ultrasonic sensors provide an in-situ method for evaluating wear severity in a contact. With ultrasonics there are two basic types of waves: longitudinal and shear waves. Ultrasound is used as a non-destructive evaluation technique which can be used for the identification of invisible sub-surface microcracks or defects. The technique can also be used to monitor material loss from a sliding surface that undergoes wear, using a normal-incident compressional wave to detect sub-surface lateral cracks [57]. Ahn and Kim [58] investigated the capability and sensitivity of ultrasonic pulse-echo technique as an in-situ continuous wear measurement method (Fig. 7). A close relationship between surface and subsurface damage and the maximum echo amplitude of the compressional waves was determined. With increasing surface damage, the maximal amplitude of the ultrasonic wave decreased. By calculating the change in Time of Flight (TOF) of the ultrasonic signals the in-situ wear depth could be measured. This technique can effectively assess the level of severity of wear in a contact surface in real time.

#### 4.6. Vibration measurements

During machining operations, it is desirable to monitor tool wear and the parameters impacting it. Using indirect methods flank wear can be estimated by relating it to a measured variable such as cutting force, spindle motor current, vibration and surface roughness. Previous studies have highlighted surface roughness and vibration give a strong insight

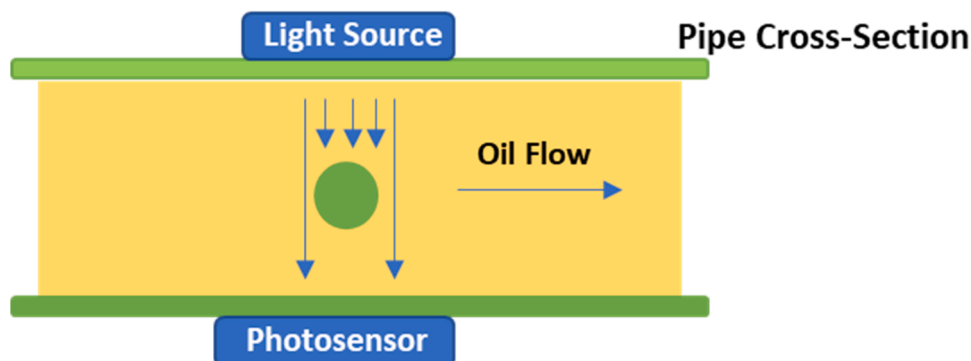

Fig. 4. Schematic diagram of an optical sensing method (after [46]).

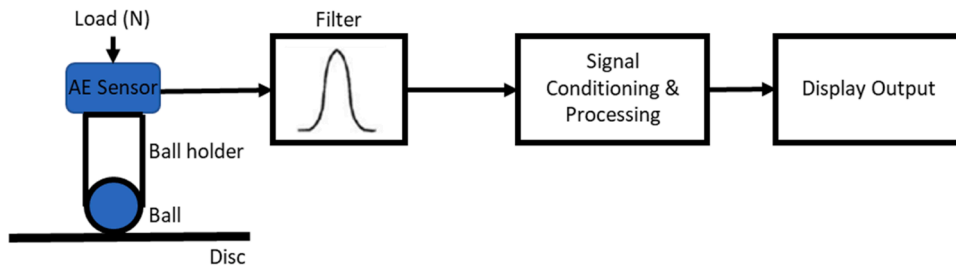

Fig. 5. Schematic of the AE monitoring system for a ball on disc sliding contact (after [49]).

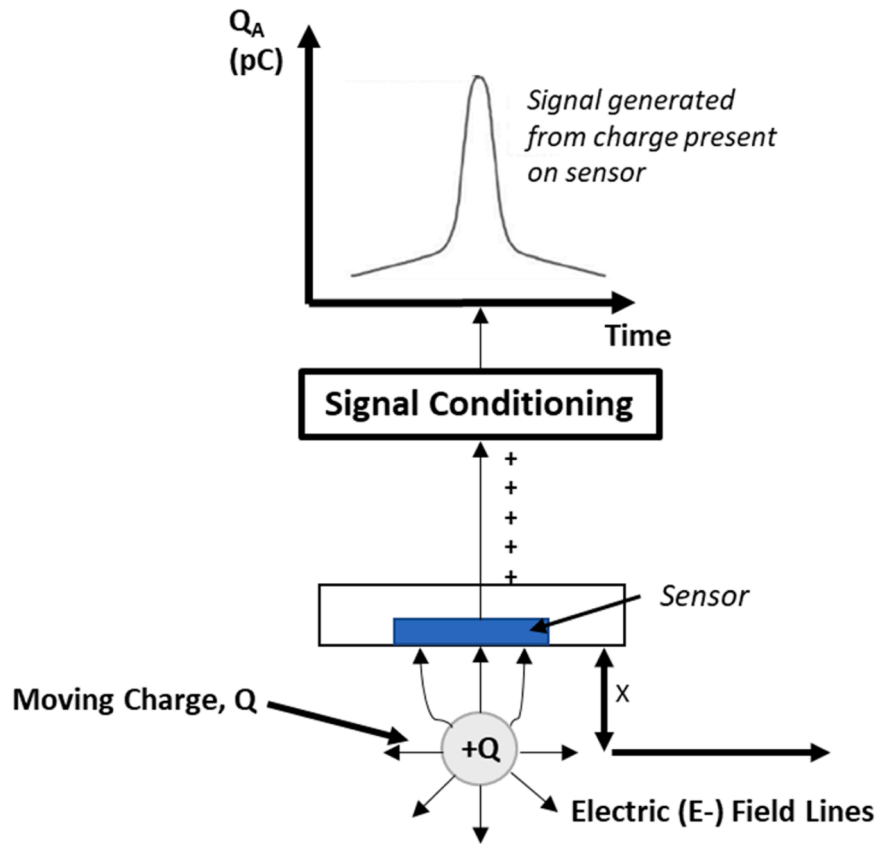

Fig. 6. Schematic illustration of the electrostatic charge sensing system (after [56]).

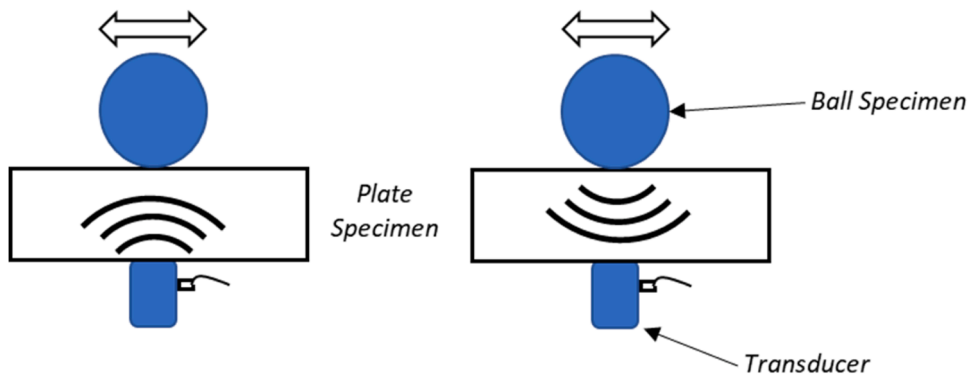

Fig. 7. Ultrasonic sensing method (after [58]).

on tool wear [59]. Ghani et al. [36] monitored vibrations and surface roughness during cutting to monitor tool wear progression. The study used two accelerometers attached to the tool holder, with the first

measuring the vibration in direction of the main cutting force and the second in the direction of the radial cutting force. Vibration signals were monitored and analysed before machining was stopped to permit flank

wear and surface roughness measurement. The study highlighted an increase in the amplitude of vibrations with increasing flank wear. Vibrations were observed to decrease at increasing speeds and at constant feed rate and depth of cut. Vibration amplitudes increased with increasing flank wear, but at a slower rate at higher cutting speeds.

## 5. Probing lubricant properties

Lubricating oil analysis is important for monitoring the wear, lubrication and condition of oil-wetted moving-pairs and can provide an early warning of the potential damage or failure of mechanical components. For decades, various monitoring techniques have been developed in both academia and industry, mainly based on measuring viscosity, total acid number (TAN) / total base number (TBN), lubricant debris, content of water and aeration, and element concentration in lubricants.

### 5.1. Viscosity

The laboratory measurement of lubricant viscosity is achieved using a range of approaches involving displacement, vibration and changes in acoustic signals in devices such as falling ball, rotary and capillary viscometers. [60]. These principles have also been used in the development of on-line sensors. However, as these types of laboratory equipment can be rather bulky and complex with larger scale moving components these approaches have sometimes been found to be unsuitable for in-situ applications. [61].

Consequently, bespoke vibration and acoustic sensors have been developed for monitoring of viscosity. Heinisch et al. [60] proposed a technique to monitor the density and viscosity of lubricant through the response of electromagnetically driven tuning forks which achieved measurement accuracies in the order of 0.01% in density, and 1% in viscosity, respectively. However, these devices were still bulky. Among all the sensors for monitoring the lubrication system of vehicles, acoustic solid-state sensors appear to be the most promising solution [61]. Quartz crystal microbalances (QCMs) are used widely in viscosity sensing and acoustic waves, generated by an alternating electrical field have been found to allow viscosity to be monitored reliably through the resonant frequency of the QCM [62].

### 5.2. Total acid number (TAN) and total base number (TBN)

The TAN of an oil reflects its level of acidity while TBN reflects the capability of an oil to resist the development of acidity in a context of "reserve alkalinity". An increase of TAN is usually caused by oxidation of an oil introducing acid contamination into lubricants, while the decrease of TBN is caused by the consumption of additives in lubricants formulated to resist the development of acidity. An increase in acid contaminants and the consumption of additives represents degradation of a lubricant and it may also reduce viscosity causing excessive wear due to loss of lubricating film thickness or corrosion. The electrochemical behaviour of lubricants is changed by their acidity so various techniques with immersed electrodes used for on-line condition monitoring of lubricants.

Smiechowski and Lvovich [63] fabricated chrono-potentiometric sensors based on iridium oxide film deposited on electrodes to monitor lubricant acidity. Ion-selective electrodes (ISE) fabricated by thick-film screen printing technology [64,65] and solid-state sensors based on ion-sensitive field-effect transistor technology with a cation-conducting polymer film [66] have also been used to detect changes in oil acidity, exploiting the fact that the voltage between electrodes has a negative correlation with acidity. In addition to techniques based on electrochemistry, CO<sub>2</sub> pressure sensors have also been explored to monitor lubricant TBN. This approach relies on the fact that CO<sub>2</sub> is produced through a chemical reaction between acid contaminants and CaCO<sub>3</sub> an alkaline additive sometimes used in oils. [67]. The

consumption speed of additives in lubricants was reflected by changes in the partial pressure of CO<sub>2</sub>.

### 5.3. Water and aeration content

Water contamination in oil is a major issue in lubrication systems. It is typically caused by the condensation of water from ambient environment, or the leakage of coolant. Water contamination leads to increased wear debris formation and more severe oxidation of lubricants [60].

Schuller et al. [68] proposed a method to measure the concentration of water in an oil/water dispersion using a circular single-electrode capacitance probe based on the change in frequency of an oscillator due to the dielectric property of the lubricants. However, the dielectric property of the lubricants can also be influenced by other factors including wear debris, acidity, etc. [69], and this makes it difficult to reliably measure water content in lubricants using this method in complex systems.

Recently, sensors based on optical methods have been proposed to monitor the water content in a fast and simple way. Optical fibres sensor which use a sensing technique based on evanescent-field absorption combined with dielectro-phoresis has been proposed to monitor the water content in lubricants [70]. The approach has been found to be applicable even for oil highly contaminated with soot. A monitoring system based on visible-near-infrared spectroscopy technology which was able to determine the water content quickly and accurately was proposed [71].

In addition to contamination by water, air can also get into the lubricant systems, especially in high-speed machines. This effect can also lead to increased wear and oil oxidation. An image analysis method [72] and X-ray adsorption [73] have both been proposed to monitor oil aeration, but the stability and accessibility of these approaches still needs further improvement.

### 5.4. Debris analysis

Wear debris in lubricants generally has a strong negative influence on the tribological behaviour of moving contracts. The concentration of wear debris, as well as the size and morphology of wear debris particles can be used to evaluate the wear rates and the health of machine elements [41,74].

Various techniques have been proposed for the real-time monitoring of wear debris. These can be divided according to their principle of operation into acoustic, electrical, optical, and magnetically based methods.

An ultrasonic pulse sensor with a flow recess structure was proposed by Du and Zhe [75], which ensured all the wear debris (metallic and non-metallic) could be counted and sized. Ultrasonic sensors with three transducers were developed by Nemarich et al. [76], which were able to distinguish between wear debris and air bubbles by comparing the reflected pulse echoes received by different transducers. Edmonds et al. [77] found that the acoustic reflection coefficient for wear debris and air bubbles are different, thus allowing them to be distinguished by the polarity or the waveform of the echoes. Acoustic-based sensors can successfully differentiate between wear debris and air bubbles, but the type of material that solid wear debris is formed from is hard to distinguish as solids tend to have similar acoustic reflection coefficients [75].

Electrical-based sensors have also been proposed for wear debris monitoring. A microfluidic sensor based on the capacitance Coulter counting principle was proposed by Murali et al. [78]. It was found to be able to distinguish wear debris with different sizes through the strength of the pulse signal. However, it was not able to detect dielectric debris, and water droplets were also found to generate a strong signal, which suppressed the value of the sensor for wear debris detection in engineering applications. Electrostatic sensors have also been developed



based on detecting the positively charge characteristics of adhesive wear debris [79–82].

Optically-based oil debris sensors can be mainly divided into photoelectric sensors based on the light extinction / light scattering phenomena, and imaging sensors. Light extinction sensors which employ a uniform light source [44,83], and light scattering sensors which use a laser light source [84] have been proved capable approaches for the on-line monitoring of oil debris larger than 5  $\mu\text{m}$ . However, the results are influenced by air bubbles, the transparency of oil, and the overlapping projections of wear debris outlines [85].

Imaging sensors can provide information that is hard to obtain from other monitoring methods, but imaging is limited in practical applications because lubricating oil tends to turn increasingly opaque in service. In addition, the mobility of wear debris is limited, and this can influence the reliability of a debris image. Aiming to address these shortcomings, studies have been carried out on an on-line visual ferrograph to obtain images of wear debris precipitated by a magnetic field [44,86,87], but the approach is still restricted by the overlapping of wear debris and image quality. Magnetic-based oil debris sensors (Fig. 8) have attracted attention for decades and magnetic chip detectors, which have been widely used in industrial applications, can detect ferrous wear debris in lubricant flows generating a pulse signal ostensibly for each particle [88]. By using the differing responses of ferromagnetic, paramagnetic and diamagnetic materials to external magnetic fields, the use of inductive sensors has been extended to classify ferromagnetic debris and non-ferromagnetic debris [89], and this approach has been improved by utilizing a triple-coil structure [90].

Microfluidic devices based on the inductive Coulter counting principle have also been investigated [91–93]. They have been found to have high sensitivity, high throughput, and high capacity for the monitoring of individual wear particles along with high accuracy in detecting the particle size.

### 5.5. Element concentration

Changes in the concentration of differing elements in lubricating oil and wear debris can reflect the condition of lubricants and the wear of components. Various spectroscopic strategies have been used to monitor the condition of lubricants. Infrared (IR) spectrometry has been used to provide information about lubricant “pollutants”, additives and oil quality. However, there are limitations on the elements that can be detected and the data processing can be time-consuming, limiting the application of IR [94]. Infra-red Fourier transform spectroscopy (FTIR) is more suitable for on-line monitoring because the data can be more easily processed [94–96]. X-ray fluorescence (XRF) systems have also been developed to detect quantitative information about the elemental content of wear debris [97]. Although the elemental analysis techniques are commonly applied in used oil analysis, real-time element monitoring is still unusual in industrial applications due to the complex structure of the equipment and the relatively high cost.

## 6. Coatings as sensors

The failure of components in mechanical systems leads to a reduction in efficiency and economic loss for commercial organisations. For example, it has been indicated that 6.8% of the downtime of machining centres is caused by the failure of machining tools [98]. Monitoring the damage and wear of components is essential for reducing the downtime of the machines, and as a result, coating sensors have been developed to directly monitor the real-time condition of the machine parts. They can be sub-divided into contact and non-contact arrangements. In this section, we also touch on the triboelectric nanogenerators as an emerging area in in-situ sensing.

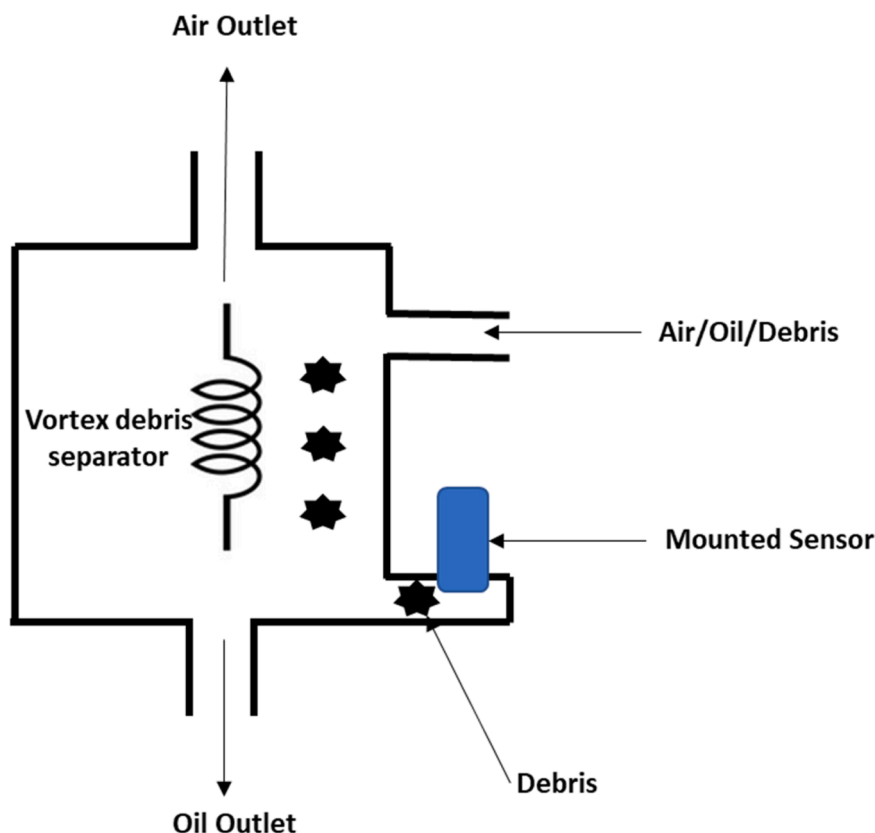

Fig. 8. Vortex separator of a quantitative debris monitoring sensor (after [88]).

## 6.1. Contact sensors

### 6.1.1. Wear measurement

Coating sensors, consisting of a thin film of Ni-Fe, were developed for the magnetic recording industry in the 1980s addressing a high demand to accurately monitor the very small amounts of wear in recording heads [99]. The sensors consisted of thin metal films deposited onto non-conductive substrates. The resistance of these films changed with the wear of film, making it possible to evaluate wear by monitoring changes of resistance. However, the monitored resistance could also be influenced by changes of temperature. Consequently, materials with lower temperature sensitivity, such as tungsten and molybdenum, could be adopted to improve the accuracy of the wear sensors which use the resistive technique, while materials such as zinc and aluminium, which have higher temperature sensitivity, could be used to measure temperature [99]. Various vacuum deposited coating sensors consisting of thin films of aluminium, platinum, tantalum, aluminium oxide, tantalum oxide, and borosilicate glass were fabricated by Kreider and Ruff in 1990s to monitor wear and temperature in bearing applications [100, 101]. The laminated sensors had one or more insulator / metallic layers and were directly deposited on the surface of bearing. The sensors were designed to have a similar wear behaviour to the bearing materials and were deposited into a small area embedded into the bearing contour. It was found that coating sensors could continuously monitor the wear depth and surface temperature of sliding bearing. Challenges in adopting this approach more widely involve developing an adequate hardness, toughness and low ductility for the conducting film, while the low conductivity, hardness and strength are the key aspects for the insulating film. High adhesion between the conducting films and the insulating films is also needed to ensure the high performance of the deposited coating sensors.

Wear sensing using a sacrificial organic layer was considered by Sakka et al. [102]. The temperature underneath the organic layer during friction tests was recorded, and the wear depth was found to correlate with the temperature. The parameters for the most accurate correlation between wear depth and temperature was optimized by numerical simulation. It was found that the thermal gradient induced by the difference between the thermal conductivity of the epoxy sacrificial layer (less than 0.4 W/mK) and the substrate (more than 4 W/mK) allowed heat dissipation and produced a thermal regime enhancing effective wear sensing.

### 6.1.2. Load measurement

When sensor coatings are deposited on the component surface, the wear resistance of the sensor materials is an important factor in maintaining a long service life for the sensor. Amorphous diamond-like carbon (DLC) has been used in high performance components in some industrial equipment due to its excellent lubrication and wear-resistance capabilities. Biehl et al. [102] found that DLC films showed a noticeable piezoresistive behaviour in addition to having excellent tribological properties, making them suitable for direct load

measurement on the friction surface of machine parts. In contrast to traditional strain gauges as load sensors, thin film coating-based sensors can be used in both static and dynamic load measurements.

Developments in the structure of thin film sensor systems has generally involved the addition of further layers. Biehl et al. [103] have investigated using a Cr layer deposited onto piezoresistive DLC with a wear-resistant silicon doped DLC layer on top as protection (Fig. 9). The layered sensor layer was deposited on a spindle shaft and had a minimum resistance when the shaft lost the contact with the workpiece. This arrangement made it suitable for monitoring both the applied load and the effectiveness of the machining process [103]. In other study, the function of the coating sensor system has been further developed by adding a Cr element for temperature monitoring to a DLC layer for measuring the load [104].

## 6.2. Non-contact sensors

Coating sensing technologies based on optical methods have been developed to monitor wear in non-contact mode. One approach has been to fabricate a double layer or multilayer coating with different optical properties in each layer to determine the wear condition of those coatings. Rasmussen et al. [105,106] fabricated a double layer coating on a steel substrate with a TiAlN layer on the top of a TiN layer. It was found that when the top layer TiAlN coating was worn out, the exposed TiN coating could be easily identified by a simple optical imaging system. This was achieved by measuring the optical appearance of TiN & TiAlN coatings.

Muratore et al. [107] fabricated an MoS<sub>2</sub> coating with embedded erbium-doped and samarium-doped yttria stabilized zirconia (YSZ) at the interface between the MoS<sub>2</sub> coating and substrate for coating health monitoring using the principle of luminescence. When the YSZ layer was exposed, the YSZ sensor layer could be activated by laser light to provide signals for wear monitoring. The mid-layer erbium-doped YSZ coating and the interfacial samarium-doped YSZ coating exhibited different signals so the wear depth could be directly obtained. The embedded YSZ layer was also found to extend wear life in comparison to a single layer of MoS<sub>2</sub> coating by more than 30 times due to the MoS<sub>2</sub> transfer layer formed on the surface of YSZ layer. Fang et al. [108] fabricated an Al/AlN multi-layered coating system with an erbium-doped AlN layer as luminescence sensor [107]. Fang et al. [109] further investigated the influence of substrate temperature on the photoluminescence properties of the erbium-doped AlN film. It was found that with the substrate temperature at 300 °C, the photoluminescence of the Er<sup>3+</sup> was enhanced.

Another commonly used approach in thin film sensor design is to dope sensory materials which have specific optical properties into coating. Salee et al. deposited an epoxy resin coating containing luminescent ZnS:Cu powder [108] and silica/CdSe/ZnS quantum dots [109] in the amorphous carbon coating for wear monitoring. The retained thickness of the amorphous coating could be estimated by the luminescent intensity. Wear estimates compared well with data measured

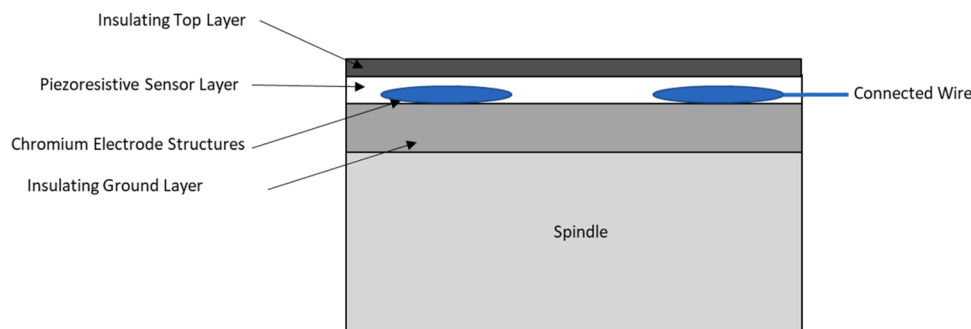

Fig. 9. Schematic of the thin film sensor system deposited on a spindle using the PVD coating process (after [103]).

with a profilometer [109]. He et al. [112] doped  $\text{MAl}_2\text{O}_4$ :  $\text{Eu}^{2+}$ ,  $\text{Dy}^{3+}$ ,  $\text{M} = \text{Sr, Ba}$  into composite coatings with different copper–aluminium alloy matrixes as luminescent layer for coating health monitoring. When the top sensory layer was worn out during wear, the luminescence disappeared in the wear track region, but was still observable in the unworn regions. The disappearance of the luminescence indicated the damage to the deposited coating. The sensory layer was also used as a mid-layer between the top functional layer and the substrate. In this arrangement, the luminescence appeared when the top functional coating was worn out. With both strategies, the luminescent layer was found to successfully monitor the wear condition of the coatings.

### 6.3. Triboelectric nanogenerators

Recently, the concept of the “self-powered” sensor has been proposed (Fig. 10), providing a maintenance-free and sustainable operation which has potential application in a wireless sensor network [110,111], as robot system [112] or condition monitoring arrangement [113]. Triboelectric nanogenerators (TENGs) were first proposed by Wang in 2012 [114] as devices which can convert mechanical energy into electricity through electrostatic induction and the triboelectric effect [115, 116] thus forming a device potentially suitable to support “self-powered” sensor systems. Li et al. [117] fabricated a ball-bearing structure based TENG with Cu interdigital electrodes deposited on a glass epoxy substrate. The output of the TENG sensor was attributed to the rolling electrification between the bearing balls and interdigital electrodes. Using the output signals, an arrangement for damage detection of the PTFE balls was realized without demounting the bearing. In addition, the rotational speed could be calculated using the timing of the periodic output signals.

Using the concept of the TENG, a triboelectric rolling ball bearing (TRBB) was developed by Han et al. [118], which exhibited self-powering and self-sensing properties. The electrode was placed on the surface of the outer ring of bearing to avoid the direct contact between the bearing balls and electrode. The service life of the TRBB was significantly extended, and the changes in frequency and output current with rotational speed made it possible to monitor the rotational speed.

In summary, it is apparent that coating sensors have been widely used to monitor the condition of mechanical parts. The further development of multi-functional coating sensors offers a significant potential for the development of sensors which can be used more widely in industrial applications. The recent development of TENGs and their use in conjunction with sensing has demonstrated that there is potential to form relatively compact and autonomous sensor systems within machine elements. With the development of more powerful TENGs, the possibly arises to communicate measurements from these sensors to

external control systems using wireless connections.

## 7. Discussion

The prediction of tribological failure in machine elements is typically achieved by costly trial-and-error testing using model contacts. In an attempt to understand tribological systems many analytical models have been developed for wear and friction. However, they can only be used with a limited degree of confidence in a narrow window of operating conditions [119]. New approaches are needed to truly realise a vision which leads to the increased reliability of machine elements and, improved performance of critical assets.

Condition monitoring is currently one of the main applications for sensors in machine components. Encoder bearings which measure speed, number of rotations, etc., have long been available, but at least one major rolling element bearing manufacturer now supplies a range of bearings which use wireless communication technology to enable bearing to measure and communicate their operating state [120]. This system uses internally powered sensors and data acquisition to measure rotating speed, operating temperature, vibration levels and bearing load for condition analysis. A well-known polymer bearing manufacturer also supplies a range of simple “sensorised” polymer bearings [121] in which wear of a sensor layer in a polymer bearing is used to relay data which can be displayed on a “traffic light” system to indicate the wear status of both rotating and linear dry bearings.

A second area of application is in the control of many millions of tribotronic devices already in common daily use. They have conventional feedback systems, actuators and sensors, but they are not recognised as “tribotronic”. They include familiar arrangements such as anti-lock braking systems and active clutch management in automatic transmissions widely used automotive applications as well as active electromagnetic bearings which are common in vacuum systems.

Closed loop control as it is employed these latter systems above does not require a detailed theoretical understanding of the system it manages, in the same way that thermostatic control of a domestic home does not require a detailed model of the thermal characteristics of a house in order to manage the internal temperature effectively. The authors anticipate that the first tribotronic systems will manage the operation of machine elements in a similar fashion. Developments including controlled thrust pad bearings [122], tilting pad journal bearings [123] and seals [124] are already being developed in research projects with the aim of improving various aspects of their performance. For example, to control bearing stiffness to mitigate rotational instability and to improve operational efficiency.

One of the main technical challenges in developing active tribological components is to design suitable actuation mechanisms. There are several types of actuators. Mechanical components can obviously be

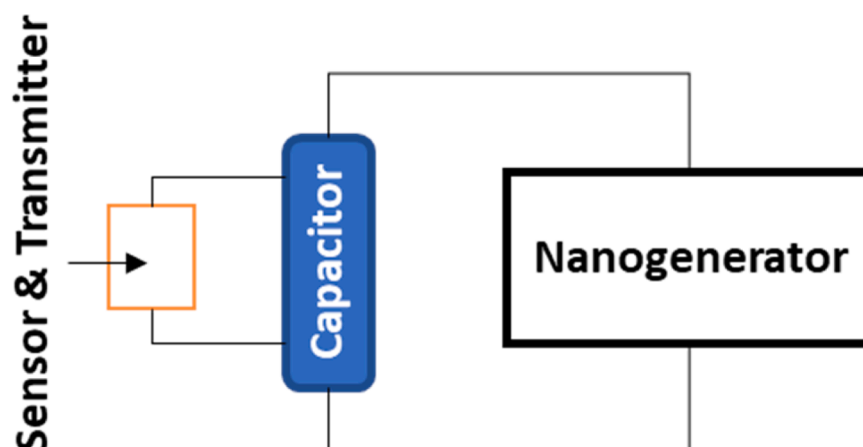

Fig. 10. The prototype of an integrated self-powered system by using a nanogenerator as an energy harvester (after [111]).

adjusted using electro-mechanical/pneumatic/hydraulic arrangements [125]. However, stimulating the properties of lubricants and additives requires chemical and/or energetic stimulation which may be externally initiated, for example by an electric/magnetic field [126] or more conventional mechanically initiated [127] and the replenishment of functional coatings requires on-board re-coating arrangements [128]. A second challenge of tribotronic control is that in order to implement effective feedback adjustment it is essential to have some kind of knowledge of the time constant of the system. For example, changing the contact pressure in an elastomeric lip seal does not result in an instantaneous change in its operating conditions as polymers are visco-elastic. In many cases the response time of these components is of the order of a few minutes. Similarly, other large systems such as bearings and their lubrication supply also take a period of time to respond to actuated changes due to the “thermal inertia” of the system. The challenges posed by actuator design and system response are the subject of existing research programmes and in cases where the progress of these studies informs the solution of industrial challenges, investment in development and practical implementation will follow.

The term ‘fourth Industrial Revolution’, introduced in 1988 [129], is commonly referred to as Industry 4.0. It loosely involves the emergence of connectivity of computing systems, the development of the internet and the widespread use of sensors. Many think that this will rapidly evolve to incorporate the use of artificial intelligence (AI)/machine learning (ML), personalisation of goods, collaborative use of robots and big data and there is a discussion about whether this evolution may constitute yet another industrial revolution (which some refer to as Industry 5.0). Irrespective of the nomenclature, all these technologies and developments will inevitably arise with AI/ML, wireless communication combining with sensors to boost industrial productivity and efficiency. In particular, the Fourth Industrial Revolution fosters what has been referred to as the “smart factory”, a system involving people, machines and resources communicating and collaborating in a social network of sorts to allow optimal usage of resources. Industry 4.0 also involves using automation systems in industry that will help to manage value and supply chains and their connected processes.

Sensorised and / or active tribological components can be crucial in Industry 4.0, as they could play a role in several key areas such as cyber physical systems, electronic maintenance monitoring and diagnostics, technologies for energy saving and manufacturing solutions. The most direct connection between Industry 4.0 and tribology lies in the association between information and communication technologies, when tribological data is transferred and shared between numerous devices using the internet and wireless connections. This is where sensors play a central role and there is a strong need for reliable and affordable on-line sensors to provide real-time data related to the condition of both, machine components and lubricants. The existence of integrated industrial automation systems helps to develop even more innovative features through networking with stakeholders horizontally and vertically, which helps to create connections between the cyber and physical worlds.

Today, there is a high demand for extending the service life and maintenance interval of machines while reducing the volume of lubricants used to suppress the harm to environment. Collecting information with multiple sensors to improve detection of lubricant degradation is central to extending the lifecycle of effective lubricant use. However, novel data processing solutions are also needed for the reliable deployment of multiple sensor systems. Although on-line sensors for monitoring oil degradation have been used in aircraft, automotive applications and other areas, the more general application of on-line lubricant condition sensors is still at an early stage and far from widespread. In the future, a higher demand is anticipated for low-cost miniaturised sensors which have enhanced reliability and capability to promote their use for oil condition monitoring.

Engineers understand the limitations of wear models and recognise a need for a shift from physical modelling-based approaches to

establishing a new data-driven frameworks for tribology research and management. Instead of feeding sensor data into analytical models, future approaches will also employ machine learning algorithms to establish the performance of tribological systems. Large data sets will be generated from multiple sensors, and machine learning algorithms will analyse this large pool of real-time tribological data to identify subtle relationships between multi-sensor signals to define failure signatures that can be used to define the footprint of the lifecycle of a tribological system. This will provide a semantic insight and allow operators to distinguish effectively between “normal-operation” and “pre-failure” signals. A combined approach involving supervised machine learning (for known tribological conditions) and unsupervised learning (for the unknown tribological conditions) is likely. With extended use, these machine learning models will have the potential to be fine-tuned, to establish increasingly reliable recognition of the tribological process in operation to recognise early catastrophic damage warning signs.

Machine-learning to analyse big data sets from multiple online sensors, is of course already widely researched as a tool for establishing digital signatures to indicate inherent failures. In some cases, these are failures of tribological interfaces. Further use of sensors in tribological components will support the shift in industrial tribological analytics. For example, by transforming traditional ‘passive’ surfaces into ‘active’ devices to facilitate the availability of (digital) data on component condition and duty.

Machine learning and sensor fusion is already finding application in commercial settings for the monitoring of production equipment. One example is the approach to Industry 4.0 adopted by a major machine supplier [130] in which connectivity is deployed on client machines operating in the field along with machine learning to gather data and “learn” to identify machine status for fault finding/prediction.

The value of sensors and ML for condition monitoring applications is obvious, but these technologies can also support predictive capability. For example, evaluation of the remaining useful life of a bearing could be based on an accurate historical record of its real duty allowing individual bearings to have estimated remaining life data available to operators. Additionally, sensors and ML may be a critical element in facilitating the incorporation of intelligence and actuators for autonomous feedback-based control of tribological components in Tribotronics [131]. Such components have significant potential in applications where machines operate in remote or inaccessible locations, such as offshore wind turbines, or where they are used in safety critical applications such as aircraft engines. The potential for application within the concept of Industry 4.0 means that applications for tribotronic components are likely to grow and sensors for tribological parameters will be a critical part of this expansion.

## 8. Conclusions

This paper reflects on the state-of-the-art in sensors for tribology. The purpose of this work was to summarise examples of methods for measuring friction, wear and lubricant properties. As digitalisation is increasingly affecting all technological sectors, it is important to take stock of the measurement methods currently used. Tribology is beginning to evolve towards Tribotronics by combining machine elements and electronic components to create active systems and this offers the potential for deep integration with a broader Industry 4.0 environment by continuous monitoring and adjustment of tribosystems, resulting in increased reliability, machine efficiency and lifetime.

Sensors will become more reliable, smaller and cheaper. As this happens, they will become more ubiquitous and readily available for engineers designing tribological systems. Sensor coatings in particular are an exciting development, where sensing capability is embedded within the surface, allowing for better integration within the tribological interface.

This paper has reviewed some established sensing methods for measuring friction, wear and lubricant properties. However, it is not

intended to be an exhaustive review of sensor capability. It also does not aim to address the measurement of all tribological parameters. For example, important parameters such as the measurement of lubricating film thickness/extent, lubricant leakage and tribofilm development are not covered here (but are covered in other literature [127,132,133]). The point of the paper is that field of sensing in tribology is evolving quickly and new discoveries in surface science, materials, signal processing, as well as the rapid development of increasingly sophisticated approaches in additive manufacturing along with the capability of TENGs, will allow the development of new approaches in tribological monitoring and control. As the surfaces become part of a bigger connected systems, they need to incorporate more sensing, active and responsive capabilities. Therefore, tribological surfaces cannot be designed and exploited in isolation from the context of connected cyber-physical systems.

In order to stimulate progress and further scientific discoveries, we propose the development of national and international thematic groups and networks focusing on the subject of digital tribology and sensing. This could take a form of a national special interest groups, dedicated international conference sessions, journal special issues, and dedicated online seminars. A good example of such initiative is the UK based NetworkPlus in Digitalised Surface Manufacturing [134]. The network has been funded by the UK Research Council and it brings together the diverse expertise and capabilities in UK academia to enhance digitalisation in surface manufacturing and to move the sector forward to meet the Industry 4.0 challenges.

#### Declaration of Competing Interest

The authors declare that they have no known competing financial interests or personal relationships that could have appeared to influence the work reported in this paper.

#### Data availability

No data was used for the research described in the article.

#### References

- [1] A. Bernhard, How the Obscure Science of Rubbing Built the Past and Will Shape the Future, 2020. (<https://www.popularmechanics.com/science/a31996381/w-hat-is-tribology/>).
- [2] Ciulli E. Tribology and Industry: from the Origins to 4.0. *Front Mech Eng* 2019;5:55.
- [3] Popov VL. Is tribology approaching its golden age? Grand challenges in engineering education and tribological research. *Front Mech Eng* 2018;4:16.
- [4] Chapter 1 - Tribology from Antiquity to Our times\* \*This paper was published, in French, in the Bulletin de l'Union des Physiciens, No. 689, pp. 1531–1560, 1986. Two books have been particularly useful in writing this Chapter. The first one, without which we would not have been able to make this presentation, was written by Duncan Dowson: «History of Tribology». The second book is that of Bertrand Gilles: «Histoire des Techniques», in: J. Frêne, D. Nicolas, B. Degueurce, D. Berthe, M. Godet (Eds.), Tribology Series, Elsevier1990, pp. 1–25.
- [5] Dowson D. History of tribology. London: Professional Engineering Publ; 1998.
- [6] W.J. Bartz, History of tribology-the bridge between the classical antiquity and the 21st century, na2001.
- [7] Glavatskih S, Höglund E. Tribotronics—towards active tribology. *Tribol Int* 2008; 41(9–10):934–9.
- [8] Rouf S, Raina A, Ul Haq MI, Naveed N. Sensors and tribological systems: applications for industry 4.0. *Ind Robot: Int J Robot Res Appl* 2022;49(3):442–60.
- [9] M.S. Bahrudin, S.F. Abdullah, M.R.B. Khan, Friction measurement system using load cell for Tribotronic system on Pin-On-Disc (POD) tribometer, IOP Conference Series: Earth and Environmental Science, IOP Publishing, 2013, p. 012114.
- [10] Gardos M. The problem-solving role of basic science in solid lubrication. *New Dir Tribol* 1997;229.
- [11] Czichos H, Becker S, Lexow J. Multilaboratory tribotesting: results from the versailles advanced materials and standards programme on wear test methods. *Wear* 1987;114(1):109–30.
- [12] Czichos H, Becker S, Lexow J. International multilaboratory sliding wear tests with ceramics and steel. *Wear* 1989;135(1):171–91.
- [13] D. Howieson, The Future of Condition Monitoring, 2014. <https://evolution.skf.com/en/the-future-of-condition-monitoring/>. 2022).
- [14] Iigus, iglidur® i.Sense: Predictive maintenance from stock. (<https://www.igus.co.uk/info/news-2019-iglidur-plain-bearings-isense>). 2022).
- [15] Iigus, P4.1 rol e-chain. (<https://www.igus.co.uk/info/e-chains-p4-1>). 2022).
- [16] Load Cell Working Principle, 2016. (<https://instrumentationtools.com/load-cell-working-principle/>).
- [17] Liang Q, Zhang D, Wu W, Zou K. Methods and research for multi-component cutting force sensing devices and approaches in machining. *Sensors* 2016;16(11):1926.
- [18] Wan M, Yin W, Zhang W-H. Study on the correction of cutting force measurement with table dynamometer. *Procedia CIRP* 2016;56:119–23.
- [19] Scippa A, Sallèse L, Grossi N, Campatelli G. Improved dynamic compensation for accurate cutting force measurements in milling applications. *Mech Syst Signal Process* 54 2015:314–24.
- [20] Liang Q, Zhang D, Coppola G, Mao J, Sun W, Wang Y, Ge Y. Design and analysis of a sensor system for cutting force measurement in machining processes. *Sensors* 2016;16(1):70.
- [21] Yaldiz S, Ünsaçar F. Design, development and testing of a turning dynamometer for cutting force measurement. *Mater Des* 2006;27(10):839–46.
- [22] Kim J-D, Kim D-S. Development of a combined-type tool dynamometer with a piezo-film accelerometer for an ultra-precision lathe. *J Mater Process Technol* 1997;71(3):360–6.
- [23] Liu M, Zhang Z, Zhou Z, Peng S, Tan Y. A new method based on Fiber Bragg grating sensor for the milling force measurement. *Mechatronics* 2015;31:22–9.
- [24] Albrecht A, Park SS, Altintas Y, Pritschow G. High frequency bandwidth cutting force measurement in milling using capacitance displacement sensors. *Int J Mach Tools Manuf* 2005;45(9):993–1008.
- [25] Gomez MF, Schmitz TL. Displacement-based dynamometer for milling force measurement. *Procedia Manuf* 2019;34:867–75.
- [26] Shin B-C, Ha S-J, Cho M-W, Seo T-I, Yoon G-S, Heo Y-M. Indirect cutting force measurement in the micro end-milling process based on frequency analysis of sensor signals. *J Mech Sci Technol* 2010;24(1):165–8.
- [27] Li X, Li H-X, Guan X-P, Du R. Fuzzy estimation of feed-cutting force from current measurement—a case study on intelligent tool wear condition monitoring. *IEEE Trans Syst, Man, Cybern, Part C (Appl Rev)* 2004;34(4):506–12.
- [28] Li X. Development of current sensor for cutting force measurement in turning. *IEEE Trans Instrum Meas* 2005;54(1):289–96.
- [29] Jeswiet J, Arentoft M, Henningsen P. Methods and devices used to measure friction in rolling. *Proc Inst Mech Eng, Part B: J Eng Manuf* 2006;220(1):49–57.
- [30] Van Rooyen GT, Backofen W. A study of interface friction in plastic compression. *Int J Mech Sci* 1960;1(1):1–27.
- [31] Lenard JG, Altan B, Bay D, Geiger K, Kopp L, Schey S, Shaw S. Tribology in metal rolling keynote presentation forming group F. *CIRP Ann* 2000;49(2):567–90.
- [32] J. Kannel, T. Dow, The evolution of surface pressure and temperature measurement techniques for use in the study of lubrication in metal rolling, (1974).
- [33] Legrand N, Lavalard T, Martins A. New concept of friction sensor for strip rolling: theoretical analysis. *Wear* 2012;286:8–18.
- [34] Brunskill H, Harper P, Lewis R. The real-time measurement of wear using ultrasonic reflectometry. *Wear* 2015;332:1129–33.
- [35] Sherrington I, Grice N, Harris E. A technique for measuring the instantaneous volumetric wear of rough surface asperities. *Tribol (Finl)* 1992;11(4):74–82.
- [36] Ghani A, Choudhury I. Study of tool life, surface roughness and vibration in machining nodular cast iron with ceramic tool. *J Mater Process Technol* 2002;127(1):17–22.
- [37] Lambrakos S, Tran N, Lagakos N, Trzaskoma-Palette P. Inverse analysis of surface degradation using optical fibers. *J Mater Eng Perform* 2006;15(4):484–9.
- [38] Merzbacher C, Kersey AD, Friebele E. Fiber optic sensors in concrete structures: a review. *Smart Mater Struct* 1996;5(2):196.
- [39] Seifert W, Westcott V. A method for the study of wear particles in lubricating oil. *Wear* 1972;21(1):27–42.
- [40] Dowson D, Dalmaz G, Childs THC, Taylor CM, Godet M. Wear particles: from the cradle to the grave. Elsevier Science; 1992.
- [41] Roylance BJ, Williams JA, Dwyer-Joyce R. Wear debris and associated wear phenomena—fundamental research and practice. *Proc Inst Mech Eng, Part J: J Eng Tribol* 2000;214(1):79–105.
- [42] D.P. Anderson, Wear particle atlas. revised, FOXBORO ANALYTICAL BURLINGTON MA, 1982.
- [43] Roylance B. Ferrography—then and now. *Tribol Int* 2005;38(10):857–62.
- [44] Yan L, ShiZhu W, YouBai X, Fang Z. Advances in research on a multi-channel online ferrograph. *Tribol Int* 1997;30(4):279–82.
- [45] Rheims J, Wriedt T, Bauckhage K. Sizing of inhomogeneous particles by a differential laser Doppler anemometer. *Meas Sci Technol* 1999;10(2):68–75.
- [46] Wei H, Wenjian C, Shaoping W, Tomovic MM. Mechanical wear debris feature, detection, and diagnosis: a review. *Chin J Aeronaut* 2018;31(5):867–82.
- [47] Bhuiyan M, Choudhury I, Dahari M. Monitoring the tool wear, surface roughness and chip formation occurrences using multiple sensors in turning. *J Manuf Syst* 2014;33(4):476–87.
- [48] Ren Q, Balazinski M, Baron L, Jemielniak K, Botez R, Achiche S. Type-2 fuzzy tool condition monitoring system based on acoustic emission in micromilling. *Inf Sci* 2014;255:121–34.
- [49] Sun J, Wood R, Wang L, Care I, Powrie H. Wear monitoring of bearing steel using electrostatic and acoustic emission techniques. *Wear* 2005;259(7–12):1482–9.
- [50] Gómez M, Hey A, D'Atellis C, Ruzzante J. Assessment of cutting tool condition by acoustic emission. *Procedia Mater Sci* 2012;1:321–8.
- [51] McBride S. Acoustic emission from lubricated and unlubricated rubbing surfaces. *J Acoust Emiss* 1989;8(1):192–7.
- [52] Jiaa C, Dornfeld D. Experimental studies of sliding friction and wear via acoustic emission signal analysis. *Wear* 1990;139(2):403–24.

- [53] Hanchi J, Klamecki B. Acoustic emission monitoring of the wear process. *Wear* 1991;145(1):1–27.
- [54] Tasbaz O, Wood R, Browne M, Powrie H, Denuault G. Electrostatic monitoring of oil lubricated sliding point contacts for early detection of scuffing. *Wear* 1999; 230(1):86–97.
- [55] R. Wood, M. Browne, M. Thew, Electrostatic charging precursor to scuffing in lubricated contacts, (1997).
- [56] Wang L, Wood R, Harvey T, Morris S, Powrie H, Care I. Wear performance of oil lubricated silicon nitride sliding against various bearing steels. *Wear* 2003;255 (1–6):657–68.
- [57] G.S. Kino, Acoustic waves: devices, imaging and analog signal processing, 1987.
- [58] Ahn H-S, Kim D-I. In situ evaluation of wear surface by ultrasound. *Wear* 2001; 251(1–12):1193–201.
- [59] Bonifacio M, Diniz A. Correlating tool wear, tool life, surface roughness and tool vibration in finish turning with coated carbide tools. *Wear* 1994;173(1–2): 137–44.
- [60] Zhu X, Zhong C, Zhe J. Lubricating oil conditioning sensors for online machine health monitoring – a review. *Tribol Int* 2017;109:473–84.
- [61] Markova LV, Myshkin NK, Kong H, Han HG. On-line acoustic viscometry in oil condition monitoring. *Tribol Int* 2011;44(9):963–70.
- [62] Saluja A, Kalonia DS. Measurement of fluid viscosity at microliter volumes using quartz impedance analysis. *AAPS PharmSciTech* 2004;5(3):68–81.
- [63] Smiechowski MF, Lvovich VF. Iridium oxide sensors for acidity and basicity detection in industrial lubricants. *Sens Actuators B: Chem* 2003;96(1):261–71.
- [64] Soleimani M, Sophocleous M, Glanc M, Atkinson J, Wang L, Wood RJK, Taylor RI. Engine oil acidity detection using solid state ion selective electrodes. *Tribol Int* 2013;65:48–56.
- [65] Soleimani M, Sophocleous M, Wang L, Atkinson J, Hosier IL, Vaughan AS, Taylor RI, Wood RJK. Base oil oxidation detection using novel chemical sensors and impedance spectroscopy measurements. *Sens Actuators B: Chem* 2014;199: 247–58.
- [66] Hyodo T, Yuto M, Tanigawa H, Tsuruoka M, Sakamoto H, Ueda T, Kamada K, Shimizu Y. Solid-state ISFET-based sensors capable of measuring acidity of lubricants. *ECS Trans* 2020;98(12):59–66.
- [67] Mujahid A, Dickert FL. Monitoring automotive oil degradation: analytical tools and onboard sensing technologies. *Anal Bioanal Chem* 2012;404(4):1197–209.
- [68] Schuller RB, Gundersen T, Halleraker M, Engbretnsen B. Measurement of water concentration in oil/water dispersions with a circular single-electrode capacitance probe. *IEEE Trans Instrum Meas* 2004;53(5):1378–83.
- [69] Raadnu S, Kleesuwan S. Low-cost condition monitoring sensor for used oil analysis. *Wear* 2005;259(7):1502–6.
- [70] Holzki M, Fouckhardt H, Klotzbücher T. Evanescent-field fiber sensor for the water content in lubricating oils with sensitivity increase by dielectrophoresis. *Sens Actuators A: Phys* 2012;184:93–7.
- [71] Liu C, Tang X, Yu T, Wang T, Lu Z, Yu W. Measurement of moisture content in lubricating oils of high-speed rail gearbox by Vis-NIR spectroscopy. *Optik* 2020; 224:165694.
- [72] Kimura Y, Kato N, Kataoka T, Takahashi K, Kikuchi T. Bubble Behavior in Engine Lubricant. *Int J Automot Eng* 2011;2(4):149–53.
- [73] Delta Services Industrials. Lubricant aeration. (<http://www.deltabeam.net/en/product/lubricant-aeration>).
- [74] Cao W, Dong G, Xie Y-B, Peng Z. Prediction of wear trend of engines via on-line wear debris monitoring. *Tribol Int* 2018;120:510–9.
- [75] Du L, Zhe J. An integrated ultrasonic-inductive pulse sensor for wear debris detection. *Smart Mater Struct* 2012;22(2):025003.
- [76] Nemarich C, Whitesel H, Sarkady A. On-line wear particle monitoring based on ultrasonic detection and discrimination. *Mater Eval* 1988;50:525–30.
- [77] J. Edmonds, M.S. Resner, K. Shkarlet, Detection of precursor wear debris in lubrication systems, 2000 IEEE Aerospace Conference. Proceedings (Cat. No.00TH8484), 2000, pp. 73–77 vol.6.
- [78] Murali S, Xia X, Jagtiani AV, Carletta J, Zhe J. Capacitive coulter counting: detection of metal wear particles in lubricant using a microfluidic device. *Smart Mater Struct* 2009;18(3):037001.
- [79] Harvey TJ, Wood RJK, Powrie HEG. Electrostatic wear monitoring of rolling element bearings. *Wear* 2007;263(7):1492–501.
- [80] Craig M, Harvey TJ, Wood RJK, Masuda K, Kawabata M, Powrie HEG. Advanced condition monitoring of tapered roller bearings, Part 1. *Tribol Int* 2009;42(11): 1846–56.
- [81] Mao H, Zuo H, Wang H. Electrostatic sensor application for on-line monitoring of wind turbine gearboxes. *Sensors* 2018;18(10):3574.
- [82] Liu R, Zuo H, Sun J, Wang L. Electrostatic monitoring of wind turbine gearbox on oil-lubricated system. *Proc Inst Mech Eng, Part C: J Mech Eng Sci* 2016;231(19): 3649–64.
- [83] Liu Y, Xie Y-B, Yuan C-J, Li Z-Y. Research on an on-line ferroglyph. *Wear* 1992; 153(2):323–30.
- [84] Noria, Automatic particle counters for fluid contamination control. (<https://www.machinerylubrication.com/Read/351/particle-counters>).
- [85] Sun J, Wang L, Li J, Li F, Li J, Lu H. Online oil debris monitoring of rotating machinery: a detailed review of more than three decades. *Mech Syst Signal Process* 2021;149:107341.
- [86] Wu TH, Mao JH, Wang JT, Wu JY, Xie YB. A new on-line visual ferroglyph. *Tribol Trans* 2009;52(5):623–31.
- [87] Wu TH, Wang JQ, Wu JY, Xie YB, Mao JH. Wear characterization by an on-line ferroglyph image. *Proc Inst Mech Eng, Part J: J Eng Tribol* 2011;225(1):23–34.
- [88] E. Harkemanne, O. Berten, P. Hendrick, Analysis and Testing of Debris Monitoring Sensors for Aircraft Lubrication Systems, 2(8) (2018) 461.
- [89] Masom RA. The development, proving and application of an in-line metal particle detector (MPD). *Br J Nondestruct Test* 1985;27:159–66.
- [90] D.M. Dave Muir, In-line oil debris monitor (ODM) for the advanced tactical fighter engine, SAE Technical Paper (1996) 961308.
- [91] Du L, Zhe J, Carletta JE, Veillette RJ. Inductive Coulter counting: detection and differentiation of metal wear particles in lubricant. *Smart Mater Struct* 2010;19 (5):057001.
- [92] Zhu X, Du L, Zhe J. A 3×3 wear debris sensor array for real time lubricant oil conditioning monitoring using synchronized sampling. *Mech Syst Signal Process* 2017;83:296–304.
- [93] Zhu X, Zhong C, Zhe J. A high sensitivity wear debris sensor using ferrite cores for online oil condition monitoring. *Meas Sci Technol* 2017;28(7):075102.
- [94] van de Voort F, Sedman J, Pinchuk D. An overview of progress and new developments in FTIR lubricant condition monitoring methodology. *J ASTM Int* 2011;8(5):1–14.
- [95] Wu T, Wu H, Du Y, Peng Z. Progress and trend of sensor technology for on-line oil monitoring. *Sci China Technol Sci* 2013;56(12):2914–26.
- [96] Adams MJ, Romeo MJ, Rawson P. FTIR analysis and monitoring of synthetic aviation engine oils. *Talanta* 2007;73(4):629–34.
- [97] R.W. Gary H., Darrell C, X-Ray Fluorescence Spectroscopy -The Next Generation of Wear Debris Analysis. (<https://www.machinerylubrication.com/Read/86/x-ray-fluorescence-spectroscopy>).
- [98] Dan L, Mathew J. Tool wear and failure monitoring techniques for turning—a review. *Int J Mach Tools Manuf* 1990;30(4):579–98.
- [99] Hahn FW. Thin film wear sensors. *Wear* 1981;74(1):157–64.
- [100] Kreider KG, Ruff AW. Materials for thin-film wear sensors. *Surf Coat Technol* 1996;86–87:557–63.
- [101] Ruff AW, Kreider KG. Deposited thin-film wear sensors: materials and design. *Wear* 1997;203–204:187–95.
- [102] Sakka MM, Bahri A, Antar Z, Elleuch K, Ponthiaux P, Drees D, Celis JP. Thermal wear sensing system: proof of the concept. *J Mater Eng Perform* 2018;27(9): 4635–44.
- [103] Biehl S, Rumposch C, Bräuer G, Hoffmeister H-W, Luig M. Development of a novel piezoresistive thin film sensor system based on hydrogenated carbon. *Microsyst Technol* 2014;20(4):989–93.
- [104] Biehl S, Rumposch C, Paetsch N, Bräuer G, Weise D, Scholz P, Landgrebe D. Multifunctional thin film sensor system as monitoring system in production. *Microsyst Technol* 2016;22(7):1757–65.
- [105] Rasmussen IL, Guibert M, Belin M, Martin JM, Mikkelsen NJ, Pedersen HC, Schou J. Wear monitoring of protective nitride coatings using image processing. *Surf Coat Technol* 2010;204(12):1970–2.
- [106] Rasmussen IL, Guibert M, Martin JM, Belin M, Mikkelsen NJ, Pedersen HC, Schou J. Optical detections from worn and unworn titanium compound surfaces. *Tribol Lett* 2009;37(1):15.
- [107] Fang L, Yin A, Zhu S, Ding J, Chen L, Zhang D, Pu Z, Liu T. On the potential of Er-doped AlN film as luminescence sensing layer for multilayer Al/AlN coating health monitoring. *J Alloy Compd* 2017;727:735–43.
- [108] Salee A, Hirata A. Demonstration of wear monitoring of amorphous carbon films with epoxy resin underlayer containing phosphor. *Tribol Online* 2013;8(4): 265–71.
- [109] Salee A, Aono Y, Hirata A. Development of amorphous carbon coating with luminescent silica/CdSe/ZnS quantum dots underlayer for wear monitoring. *Precis Eng* 2014;38(3):673–9.
- [110] Wang ZL. Toward self-powered sensor networks. *Nano Today* 2010;5(6):512–4.
- [111] Hu Y, Zhang Y, Xu C, Lin L, Snyder RL, Wang ZL. Self-powered system with wireless data transmission. *Nano Lett* 2011;11(6):2572–7.
- [112] Goldfarb M, Barth EJ, Gogola MA, Wehrmeyer JA. Design and energetic characterization of a liquid-propellant-powered actuator for self-powered robots. *IEEE/ASME Trans Mechatron* 2003;8(2):254–62.
- [113] James EP, Tudor MJ, Beeby SP, Harris NR, Glynn-Jones P, Ross JN, White NM. An investigation of self-powered systems for condition monitoring applications. *Sens Actuators A: Phys* 2004;110(1):171–6.
- [114] Fan F-R, Tian Z-Q, Lin Wang Z. Flexible triboelectric generator. *Nano Energy* 2012;1(2):328–34.
- [115] Jie Y, Ma J, Chen Y, Cao X, Wang N, Wang ZL. Efficient delivery of power generated by a rotating triboelectric nanogenerator by conjunction of wired and wireless transmissions using maxwell's displacement currents. *Adv Energy Mater* 2018;8(31):1802084.
- [116] Tang W, Han Y, Han CB, Gao CZ, Cao X, Wang ZL. Self-powered water splitting using flowing kinetic energy. *Adv Mater* 2015;27(2):272–6.
- [117] Li XH, Han CB, Jiang T, Zhang C, Wang ZL. A ball-bearing structured triboelectric nanogenerator for nondestructive damage and rotating speed measurement. *Nanotechnology* 2016;27(8):085401.
- [118] Han Q, Ding Z, Qin Z, Wang T, Xu X, Chu F. A triboelectric rolling ball bearing with self-powering and self-sensing capabilities. *Nano Energy* 2020;67:104277.
- [119] Vakis AI, Yastrebov VA, Scheibert J, Nicola L, Dini D, Minfray C, Almqvist A, Paggi M, Lee S, Limbert G. Modeling and simulation in tribology across scales: an overview. *Tribol Int* 2018;125:169–99.
- [120] P. Burge, SKF launches SKF Insight, groundbreaking intelligent bearing technology, 2013. (<https://news.cision.com/skf-uk/r/skf-launches-skf-in-sight-groundbreaking-intelligent-bearing-technology,c9401490>). 2022).
- [121] igus, Smart bearing technology. (<https://www.igus.co.uk/info/smart-bearings>). 2022).
- [122] D. Macmillan, Smith, E.H., Sherrington, I., Johns-Rahnejat, P., Development of a Novel Test Apparatus for the Evaluation of an Active Geometry Tilting-Pad Thrust

- Bearing and its Comparison with a Conventional Passive Type., LUBMAT 2023, Proceedings LUBMAT 2023, 2023.
- [123] H. Ulbrich, J. Althaus, Actuator design for rotor control, (1989).
- [124] S. Atkinson, Conference report: 17th EDF–Prime workshop, Sealing Technology 2018(10) (2018) 7–8.
- [125] I.F. Santos, Mechatronics applied to machine elements with focus on active control of bearing, shaft and blade dynamics, Technical University of Denmark, Department of Mechanical Engineering 2010.
- [126] Krim J. Controlling friction with external electric or magnetic fields: 25 examples. *Front Mech Eng* 2019;5:22.
- [127] Chen Y, Renner P, Liang H. A review of current understanding in tribochemical reactions involving lubricant additives. *Friction* 2022;1–24.
- [128] Adachi K, Kato K. In situ and on-demand lubrication by tribo-coating for space applications. *Proc Inst Mech Eng, Part J: J Eng Tribology* 2008;222(8):1031–9.
- [129] H. Kagermann, W.-D. Lukas, W. Wahlster, Industrie 4.0: Mit dem Internet der Dinge auf dem Weg zur 4. industriellen Revolution, *VDI nachrichten* 13(1) (2011) 2–3.
- [130] Bosch, Industry 4.0 at Bosch, Bosch.com, 2020.
- [131] I. Sherrington, S. Glavatskih, Tribotronics: The advent of a new paradigm for tribological systems?, 5th World Tribology Congress, WTC 2013; The Palaolimpico Iozaki TorinoC. so SebastopoliTorino, 2013, pp. 3200–3203.
- [132] Sherrington I, Smith E. Experimental methods for measuring the oil-film thickness between the piston-rings and cylinder-wall of internal combustion engines. *Tribology Int* 1985;18(6):315–20.
- [133] Visscher M, KANTERS AC. Literature review and discussion on measurements of leakage, lubricant film thickness and friction of reciprocating elastomeric seals. *Lubr Eng* 1990;46(12):785–91.
- [134] EPSRC NetworkPlus in Digitalised Surface Manufacturing, 2020. (<https://digitalisedsurfacemanufacturing.com/>).